

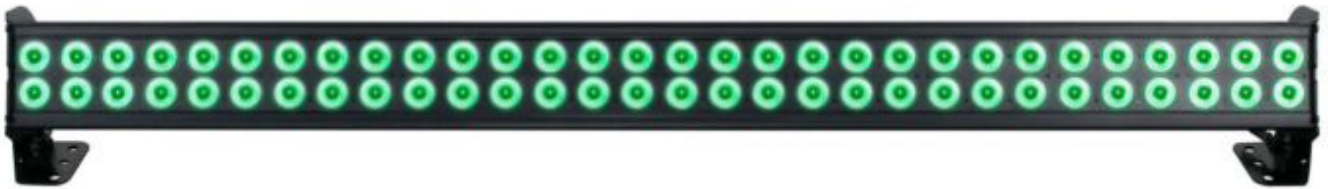

# SEVEN BATTEN 72



**User Manual**

©2021 ELATION PROFESSIONAL all rights reserved. Information, specifications, diagrams, images, and instructions herein are subject to change without notice. ELATION PROFESSIONAL logo and identifying product names and numbers herein are trademarks of ELATION PROFESSIONAL. Copyright protection claimed includes all forms and matters of copyrightable materials and information now allowed by statutory or judicial law or hereinafter granted. Product names used in this document may be trademarks or registered trademarks of their respective companies and are hereby acknowledged. All non-ELATION brands and product names are trademarks or registered trademarks of their respective companies.

**ELATION PROFESSIONAL** and all affiliated companies hereby disclaim any and all liabilities for property, equipment, building, and electrical damages, injuries to any persons, and direct or indirect economic loss associated with the use or reliance of any information contained within this document, and/or as a result of the improper, unsafe, insufficient and negligent assembly, installation, rigging, and operation of this product.

**Elation Professional USA** | 6122 S. Eastern Ave. | Los Angeles, CA. 90040  
 323-582-3322 | 323-832-9142 fax | [www.elationlighting.com](http://www.elationlighting.com) | [info@elationlighting.com](mailto:info@elationlighting.com)

**Elation Professional B.V.** | Junostraat 2 | 6468 EW Kerkrade, The Netherlands  
 +31 45 546 85 66 | +31 45 546 85 96 fax | [www.elationlighting.eu](http://www.elationlighting.eu) | [info@elationlighting.eu](mailto:info@elationlighting.eu)

**Elation Professional Mexico** | AV Santa Ana 30 | Parque Industrial Lerma, Lerma, Mexico 52000  
 +52 (728) 282-7070

## DOCUMENT VERSION



Due to additional product features and/or enhancements, an updated version of this document may be available online. Please scan the QR Code with your mobile device or visit [www.elationlighting.com](http://www.elationlighting.com) for the latest revision/update of this manual, before installation and/or programming.

Date	Document Version	Software Version	DMX Channel Mode	Notes
06/26/18	1	1.04	10 Channels	Updated release
08/22/18	1.2	1.05	No Change	Added gel/frost filter installation diagram
08/29/18	1.4	N/C	No Change	Updated Dimensional Drawings
01/22/19	1.6	N/C	No Change	Updated dimensions
05/02/19	2.0	1.09	12 Channels	Updated System Menu and DMX Channel Modes
02/05/20	2.1	N/C	No Change	Added power linking info to Installation Guidelines
08/21/20	2.2	1.10	No Change	Updated primary/secondary
11/08/21	2.3	N/C	No Change	Added RDM section

# CONTENTS

General Information	4
Limited Warranty	5
Safety Guidelines	6
Maintenance Guidelines	8
Fixture Overview	9
Installation Guidelines	10
Remote Device Management (RDM)	13
Control Panel	14
System Menu (Software Version 1.04)	15
System Menu (Software Version 1.09)	17
Pixel Zones	20
DMX Traits (Software Version 1.04)	21
DMX Traits (Software Version 1.09, RGB Modes)	30
DMX Traits (Software Version 1.09, HSI Modes)	35
Specifications	39
Dimensional Drawings	40
Optional Accessories   FCC Statement	41

# GENERAL INFORMATION

## INTRODUCTION

Please read and understand the instructions in this manual carefully and thoroughly before attempting to operate this fixture. These instructions contain important safety and use information.

## UNPACKING

Every fixture has been thoroughly tested and has been shipped in perfect operating condition. Carefully check the shipping carton for damage that may have occurred during shipping. If the carton is damaged, carefully inspect the fixture for damage, and be sure all accessories necessary to install and operate the fixture have arrived intact. In the event that damage has been found or parts are missing, please contact our customer support team for further instructions. Please do not return this fixture to your dealer without first contacting customer support. Please do not discard the shipping carton in the trash. Please recycle whenever possible.

## BOX CONTENTS

Power Cable

## CUSTOMER SUPPORT

Contact ELATION Service for any product related service and support needs. Also visit [forums.elationlighting.com](https://forums.elationlighting.com) with questions, comments or suggestions.

**ELATION SERVICE USA - Monday - Friday 8:00am to 4:30pm PST**  
323-582-3322 | Fax 323-832-9142 | [support@elationlighting.com](mailto:support@elationlighting.com)

**ELATION SERVICE EUROPE - Monday - Friday 08:30 to 17:00 CET**  
+31 45 546 85 63 | Fax +31 45 546 85 96 | [support@elationlighting.eu](mailto:support@elationlighting.eu)

**REPLACEMENT PARTS** please visit [parts.elationlighting.com](https://parts.elationlighting.com)



**THERE ARE NO USER SERVICEABLE PARTS INSIDE THIS UNIT. DO NOT ATTEMPT ANY REPAIRS YOURSELF, AS DOING SO WILL VOID YOUR MANUFACTURER'S WARRANTY. DAMAGES RESULTING FROM MODIFICATIONS TO THIS FIXTURE AND/OR THE DISREGARD OF SAFETY INSTRUCTIONS AND GUIDELINES IN THIS MANUAL VOID THE MANUFACTURER'S WARRANTY AND ARE NOT SUBJECT TO ANY WARRANTY CLAIMS AND/OR REPAIRS.**

## LIMITED WARRANTY

- A. Elation Professional hereby warrants, to the original purchaser, Elation Professional products to be free of manufacturing defects in material and workmanship for a period of two years (730 days), and Elation Professional product rechargeable batteries to be free of manufacturing defects in material and workmanship for a period of six months (180 days), from the original date of purchase. This warranty excludes discharge lamps and all product accessories. This warranty shall be valid only if the product is purchased within the United States of America, including possessions and territories. It is the owner's responsibility to establish the date and place of purchase by acceptable evidence, at the time service is sought.
- B. For warranty service, send the product only to the Elation Professional factory. All shipping charges must be pre-paid. If the requested repairs or service (including parts replacement) are within the terms of this warranty, Elation Professional will pay return shipping charges only to a designated point within the United States. If any product is sent, it must be shipped in its original package and packaging material. No accessories should be shipped with the product. If any accessories are shipped with the product, Elation Professional shall have no liability what so ever for loss and/or or damage to any such accessories, nor for the safe return thereof.
- C. This warranty is void if the product serial number and/or labels are altered or removed; if the product is modified in any manner which Elation Professional concludes, after inspection, affects the reliability of the product; if the product has been repaired or serviced by anyone other than the Elation Professional factory unless prior written authorization was issued to purchaser by Elation Professional; if the product is damaged because not properly maintained as set forth in the product instructions, guidelines and/or user manual.
- D. This is not a service contract, and this warranty does not include any maintenance, cleaning or periodic check-up. During the periods as specified above, Elation Professional will replace defective parts at its expense, and will absorb all expenses for warranty service and repair labor by reason of defects in material or workmanship. The sole responsibility of Elation Professional under this warranty shall be limited to the repair of the product, or replacement thereof, including parts, at the sole discretion of Elation Professional. All products covered by this warranty were manufactured after January 1, 1990, and bare identifying marks to that effect.
- E. Elation Professional reserves the right to make changes in design and/or performance improvements upon its products without any obligation to include these changes in any products theretofore manufactured.
- F. No warranty, whether expressed or implied, is given or made with respect to any accessory supplied with the products described above. Except to the extent prohibited by applicable law, all implied warranties made by Elation Professional in connection with this product, including warranties of merchantability or fitness, are limited in duration to the warranty periods set forth above. And no warranties, whether expressed or implied, including warranties of merchantability or fitness, shall apply to this product after said periods have expired. The consumer's and/or dealer's sole remedy shall be such repair or replacement as is expressly provided above; and under no circumstances shall Elation Professional be liable for any loss and/or damage, direct and/or consequential, arising out of the use of, and/or the inability to use, this product.
- G. This warranty is the only written warranty applicable to Elation Professional products and supersedes all prior warranties and written descriptions of warranty terms and conditions heretofore published.

### WARRANTY RETURNS

All returned service items whether under warranty or not, must be freight pre-paid and accompanied by a return authorization (R.A.) number. The R.A. number must be clearly written on the outside of the return package. A brief description of the problem as well as the R.A. number must also be written down on a piece of paper and included in the shipping container. If the unit is under warranty, you must provide a copy of your proof of purchase invoice. Items returned without an R.A. number clearly marked on the outside of the package will be refused and returned at customer's expense. You may obtain an R.A. number by contacting customer support.

# SAFETY GUIDELINES

This fixture is a sophisticated piece of electronic equipment. To guarantee a smooth operation, it is important to follow all instructions and guidelines in this manual. Elation Professional is not responsible for injury and/or damages resulting from the misuse of this fixture due to the disregard of the information printed in this manual. Only qualified and/or certified personnel should perform installation of this fixture and only the original rigging parts (omega brackets) included with this fixture should be used for installation. Any modifications to the fixture and/or the included mounting hardware will void the original manufacturer's warranty and increase the risk of damage and/or personal injury.



**PROTECTION CLASS 1 - FIXTURE MUST BE PROPERLY GROUNDED.**



**THERE ARE NO USER SERVICEABLE PARTS INSIDE THIS UNIT. DO NOT ATTEMPT ANY REPAIRS YOURSELF, AS DOING SO WILL VOID YOUR MANUFACTURER'S WARRANTY. DAMAGES RESULTING FROM MODIFICATIONS TO THIS FIXTURE AND/OR THE DISREGARD OF SAFETY INSTRUCTIONS AND GUIDELINES IN THIS MANUAL VOID THE MANUFACTURER'S WARRANTY AND ARE NOT SUBJECT TO ANY WARRANTY CLAIMS AND/OR REPAIRS.**



**DO NOT PLUG FIXTURE INTO A DIMMER PACK!  
NEVER OPEN THIS FIXTURE WHILE IN USE!  
UNPLUG POWER BEFORE SERVICING FIXTURE!  
NEVER TOUCH FIXTURE DURING OPERATION, AS IT MAY BE HOT!  
KEEP FLAMMABLE MATERIALS AWAY FROM FIXTURE!**



**NEVER LOOK DIRECTLY INTO THE LIGHT SOURCE!  
RETINA INJURY RISK - MAY INDUCE BLINDNESS!  
SENSITIVE PERSONS MAY SUFFER AN EPILEPTIC SHOCK!**



**INDOOR / DRY LOCATIONS USE ONLY!  
DO NOT EXPOSE FIXTURE TO RAIN AND MOISTURE!**

# SAFETY GUIDELINES

## **⚠ CAUTION**

**HIGH  
INTENSITY  
ULTRAVIOLET  
LIGHT**



**AVOID DIRECT EYE & SKIN EXPOSURE.  
WEAR PROPER EYE & SKIN PROTECTION.  
SEE MANUAL FOR SAFETY INSTRUCTIONS.**

**RISK GROUP 3 - RISK OF EXPOSURE TO ULTRAVIOLET UV RADIATION! FIXTURE EMITS HIGH INTENSITY WAVELENGTH OF ULTRAVIOLET UV LIGHT FROM THE UV LED. WEAR PROPER EYE AND SKIN PROTECTION. AVOID PROLONGED PERIODS OF EXPOSURE TO UV LED. AVOID WEARING WHITE COLOR CLOTHING AND/OR USING UV PAINTS ON SKIN. AVOID DIRECT EYE AND/OR SKIN EXPOSURE AT DISTANCES LESS THAN 11 feet (3.3m). DO NOT OPERATE FIXTURE WITH DAMAGED/MISSING EXTERNAL COVERS. DO NOT LOOK DIRECTLY INTO THE UV LIGHT AND/OR VIEW UV LIGHT DIRECTLY WITH OPTICAL INSTRUMENTS THAT MAY CONCENTRATE THE LIGHT/RADIATION OUTPUT. INDIVIDUALS SUFFERING FROM A RANGE OF EYE CONDITIONS, SUNLIGHT EXPOSURE DISORDERS, OR INDIVIDUALS USING PHOTSENSITIVE MEDICATION MAY EXPERIENCE DISCOMFORT IF EXPOSED TO THE ULTRAVIOLET UV LIGHT EMITTED FROM THE UV LED.**

- DO NOT TOUCH the fixture housing during operation. Turn OFF the power and allow approximately 15 minutes for the fixture to cool down before serving.
- DO NOT shake fixture, and avoid brute force when installing and/or operating fixture.
- DO NOT operate fixture if the power cord is frayed, crimped, damaged, and/or if any of the power cord connectors are damaged and do not insert into the fixture securely with ease. NEVER force a power cord connector into the fixture. If the power cord or any of its connectors are damaged, replace it immediately with a new one of the same power rating.
- DO NOT block any air ventilation slots.
- All fan and air inlets must remain clean and never blocked.
- Allow approx. 6" (15cm) between fixture and other devices or a wall for proper cooling.
- When installing fixture in a suspended environment, always use mounting hardware that is no less than M10 x 25 mm, and always install fixture with an appropriately rated safety cable.
- Always disconnect fixture from main power source before performing any type of service and/or cleaning procedure.
- Only handle the power cord by the plug end. Never pull out the plug by tugging the wire portion of the cord.
- During the initial operation of this fixture, a light smoke or smell may emit from the interior of the fixture. This is a normal process and is caused by excess paint in the interior of the casing burning off from the heat associated with the lamp and will decrease gradually over time.
- Consistent operational breaks will ensure fixture will function properly for many years.

# MAINTENANCE GUIDELINES



**DISCONNECT POWER BEFORE PERFORMING ANY MAINTENANCE!**

## CLEANING

Frequent cleaning is recommended to ensure proper function, optimized light output, and an extended life. The frequency of cleaning depends on the environment in which the fixture operates: damp, smoky, or particularly dirty environments can cause greater accumulation of dirt on the fixture's optics. Clean the external lens surface periodically with a soft cloth to avoid dirt/debris accumulation.

**NEVER** use alcohol, solvents, or ammonia-based cleaners.

## MAINTENANCE

Regular inspections are recommended to ensure proper function and extended life. There are no user serviceable parts inside this fixture, please refer all other service issues to an authorized Elation service technician. Should you need any spare parts, please order genuine parts from your local Elation dealer.

Please refer to the following points during routine inspections:

- A detailed review by an approved electrical engineer every three months, to make sure the circuit contacts are in good condition and prevent overheating.
- Be sure all screws and fasteners are securely tightened at all times. Loose screws may fall out during normal operation, resulting in damage or injury as larger parts could fall.
- Check for any deformations on the housing, color lenses, rigging hardware, and rigging points (ceiling, suspension, trussing). Deformations in the housing could allow for dust to enter into the fixture. Damaged rigging points or unsecured rigging could cause the fixture to fall and seriously injure a person(s).
- Electrical power supply cables must not show any damage, material fatigue or sediments.  
**NEVER** remove the ground prong from the power cable.



# FIXTURE OVERVIEW

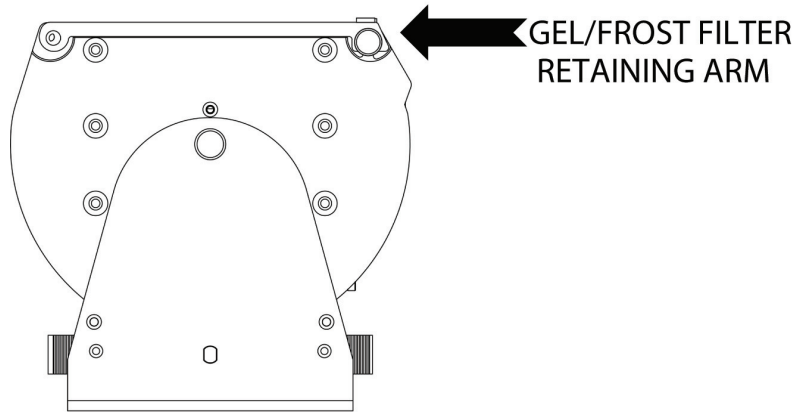
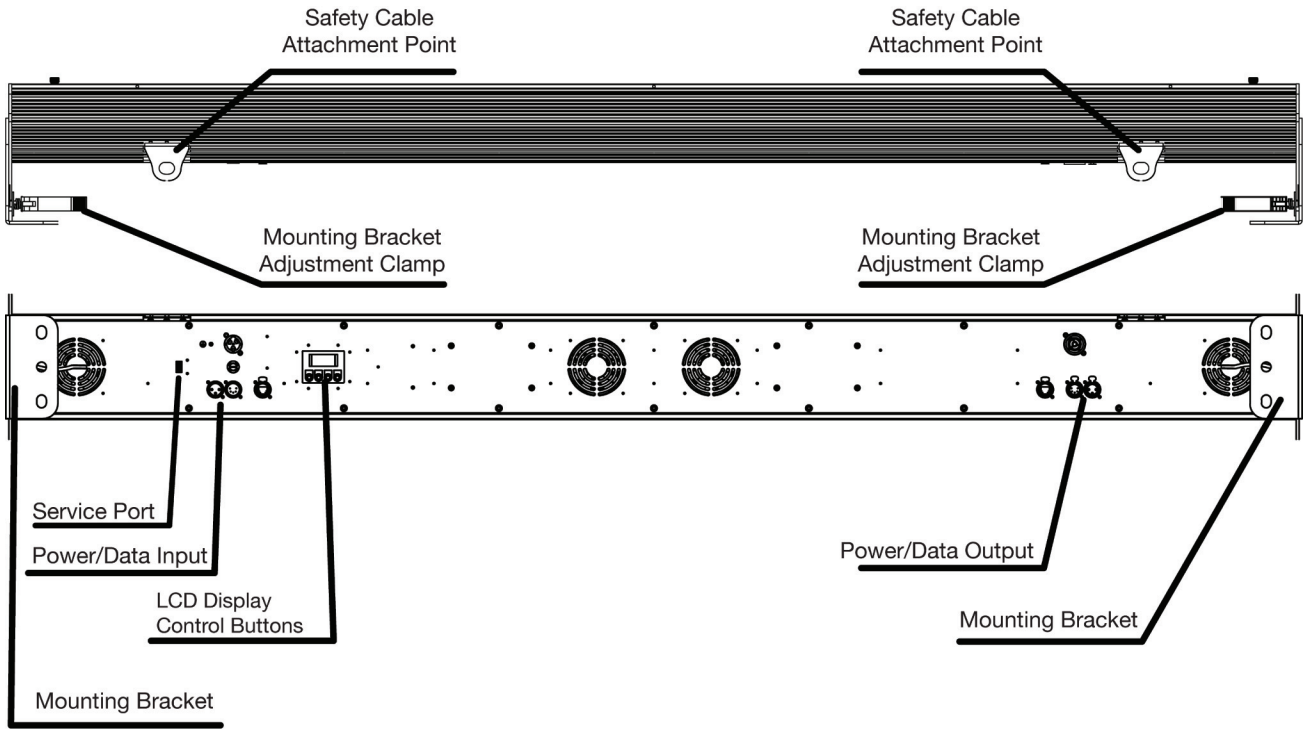

# INSTALLATION GUIDELINES



## **FLAMMABLE MATERIAL WARNING**

Keep fixture minimum 5.0 feet (1.5m) away from flammable materials and/or pyrotechnics.



## **ELECTRICAL CONNECTIONS**

A qualified electrician should be used for all electrical connections and/or installations.



**USE CAUTION WHEN POWER LINKING OTHER MODEL FIXTURES AS THE POWER CONSUMPTION OF OTHER MODEL FIXTURES MAY EXCEED THE MAX POWER OUTPUT ON THIS FIXTURE. CHECK SILK SCREEN FOR AMX AMPS.**



**DO NOT INSTALL THE FIXTURE IF YOU ARE NOT QUALIFIED TO DO SO!**



**POWER LINKING OF UNITS OF THE SAME MODEL TYPE MAY ONLY BE PERFORMED WHEN OPERATING ON 240-VOLT POWER. IN THIS INSTANCE, DO NOT POWER LINK MORE THAN TWO (2) UNITS TOGETHER, INCLUDING THE UNIT THAT IS CONNECTED DIRECTLY TO THE POWER SOURCE. NEVER EXCEED THE MAX CURRENT AND POWER DRAW LISTED ON THE SILK SCREEN.**



**DO NOT POWER LINK UNITS OF THE SAME MODEL TYPE WHEN OPERATING ON 110-VOLT POWER!**

- Fixture **MUST** be installed following all local, national, and country commercial electrical and construction codes and regulations.
- Before rigging/mounting a single fixture or multiple fixtures to any metal truss/structure or placing the fixture(s) on any surface, a professional equipment installer **MUST** be consulted to determine if the metal truss/structure or surface is properly certified to safely hold the combined weight of the fixture(s), clamps, cables, and accessories.
- Fixture ambient operating temperature range is **14° to 113°F (-10° to 45°C)**. Do not operate this fixture when ambient temperature falls outside of this range.
- Fixture(s) should be installed away from walking paths, seating areas, or areas where unauthorized personnel might reach the fixture by hand.
- **NEVER** stand directly below the fixture(s) when rigging, removing, or servicing.
- Overhead fixture installation must always be secured with a secondary safety attachment, such as an appropriately rated safety cable.
- Allow approximately 15 minutes for the fixture to cool down before servicing.

# INSTALLATION GUIDELINES

## CLAMP MOUNTING

The fixture includes adjustable mounting brackets on both ends, which include 3-position holes for versatile fixture positioning. When mounting this fixture to truss or a metal structure, be sure to secure an appropriately rated clamp (not included) to both brackets using M10 screws. Depending on the rigging position of the fixture, it may be best to use more than one clamp attached to the mounting brackets and more than one safety cable.



**MAKE SURE TO TIGHTEN BOTH MOUNTING BRACKET ADJUSTMENT CLAMPS BEFORE INSTALLING FIXTURE TO TRUSS OR A METAL STRUCTURE.**

## SAFETY CABLE

The fixture includes 2 integrated safety cable rigging points. Refer to the image below.



**ALWAYS ATTACH A SAFETY CABLE WHENEVER INSTALLING THIS FIXTURE IN A SUSPENDED ENVIRONMENT TO ENSURE THE FIXTURE WILL NOT FALL IF THE CLAMP FAILS.**



## OVERHEAD RIGGING

Overhead rigging requires extensive experience, including calculating working load limits, installation material being used, and periodic safety inspection of all installation material and the fixture, among other skills. If you lack these qualifications, do not attempt the installation yourself. Improper installation can result in bodily injury and property damage.

## POWER LINKING



**USE CAUTION WHEN POWER LINKING OTHER MODEL FIXTURES AS THE POWER CONSUMPTION OF OTHER MODEL FIXTURES MAY EXCEED THE MAX POWER OUTPUT ON THIS FIXTURE. CHECK SILK SCREEN FOR AMX AMPS. ADHERE TO THE POWER LINKING LIMITATIONS STATED IN THIS SECTION OF THE MANUAL WHEN LINKING UNITS OF THE SAME MODEL.**

# INSTALLATION GUIDELINES

## KLING-NET / ART-NET CONNECTION

When connecting the fixture to a network switch to control multiple devices, a Gigabit Ethernet Switch that supports IGMP (Internet Group Management Protocol) is required. Using a Gigabit Ethernet Switch that does not support IGMP can cause erratic behavior of all devices that have been connected to the switch. Click link below for more information about IGMP.

[https://en.wikipedia.org/wiki/Internet\\_Group\\_Management\\_Protocol](https://en.wikipedia.org/wiki/Internet_Group_Management_Protocol)

## GEL / FROST FILTER INSTALLATION

A thin precut Gel / Frost Filter (not included) can be added to alter the light output.

1. Turn thumbscrew counter-clockwise.
2. Lift retaining arm up.
3. Insert Gel/Frost Filter by sliding into groove slots on top of LED array lens.
4. Lower retaining arm into place and turn thumbscrew clockwise to secure.

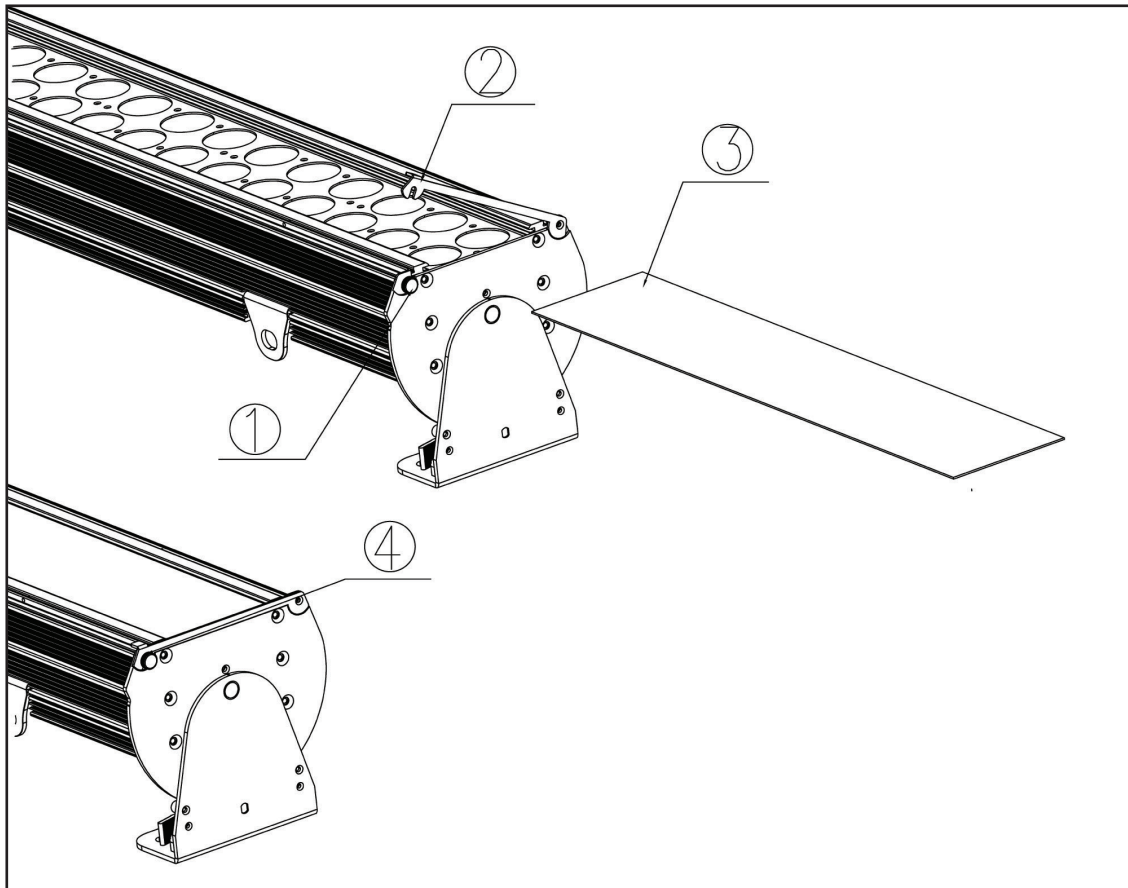

## REMOTE DEVICE MANAGEMENT (RDM)

**NOTE: In order for RDM to work properly, RDM enabled equipment must be used throughout the entire system, including DMX data splitters and wireless systems.**

Remote Device Management (RDM) is a protocol that sits on top of the DMX512 data standard for lighting, and allows the DMX systems of the fixtures to be modified and monitored remotely. This protocol is ideal for instances in which a unit is installed in a location that is not easily accessible.

With RDM, the DMX512 system becomes bi-directional, allowing a compatible RDM enabled controller to send out a signal to devices on the wire, as well as allowing the fixture to respond (known as a GET command). The controller can then use its SET command to modify settings that would typically have to be changed or viewed directly via the unit's display screen, including the DMX Address, DMX Channel Mode, and Temperature Sensors.

Please be aware that **not all RDM devices support all RDM features**, and therefore it is important to check beforehand to ensure that the equipment that you are considering includes all of the features that you require.

The following parameters are accessible in RDM on this device:

SENSOR_DEFINITION
SENSOR_VALUE
DEVICE_MODEL_DESCRIPTION
MANUFACTURER_LABEL
DEVICE_LABEL
DMX_PERSONALITY
DMX_PERSONALITY_DESCRIPTION
DEVICE_HOURS
DISPLAY_INVERT

# CONTROL PANEL

The fixture includes an easy to navigate system menu where fixture settings can be adjusted via the LCD control panel located on the back of the fixture (see image below). During normal operation, pressing the MODE button once will access the main menu. Navigate through the various sub-menus by pressing the UP and DOWN buttons. Press the ENTER button to select a specific sub-menu, then press the UP and DOWN buttons to adjust the selected sub-menu settings, and press the ENTER button again to confirm the sub-menu setting selection. Exit the main system menu at any time without making any adjustments by pressing the MODE button.

To access the system menu press and hold the MODE button for 3 seconds. The LCD Menu Control Display will shut OFF automatically after approximately 1 minutes of inactivity.

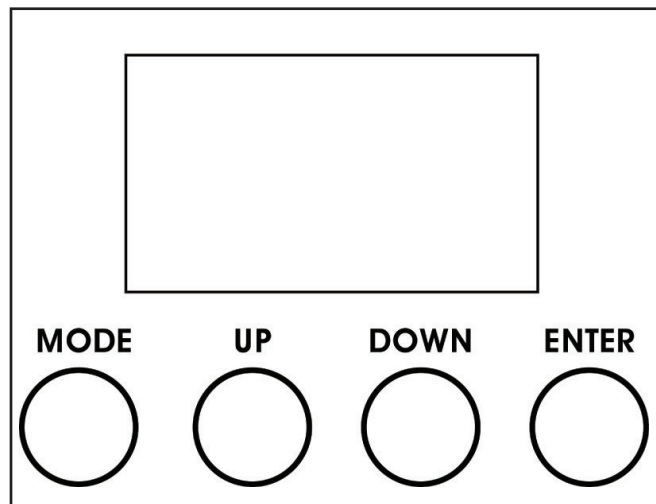

## LCD CONTROL PANEL LOCKOUT

This fixture features two variations of the control panel lockout, as described below. These can be selected from the main system menu, by navigating to Function > LCD Set > Key Lock.

When Display sub menu is set to **ON**, the LCD display backlight will turn OFF after 30 seconds. At this point, the Control Panel buttons will lock, and the display will show Locked. To unlock, press and hold the MODE button for 5 seconds.

When Display sub menu is set to **ON1**, the LCD display backlight will turn OFF after 30 seconds. At this point, the Control Panel will lock, and the display will show LOCKED\*\*\*\*\*.

To unlock follow these steps:

1. When locked, the display will show: LOCKED\*\*\*\*\*
2. Press UP, then the display will change to: LOCKED\*\*\*\* (one \* disappears)
3. Press DOWN, then the display will change to: LOCKED\*\*\* (two \* disappear)
4. Press UP, then the display will change to: LOCKED\*\* (three \* disappear)
5. Press DOWN, then the display will change to: LOCKED\* (4 \* disappear)
6. Press ENTER, then the display will change to LOCKED and then become unlocked.

# SYSTEM MENU (SOFTWARE VER 1.04)

MENU	SUB MENU	OPTIONS / VALUES	DESCRIPTION	
Address	Set ADDR	001 - xxx	DMX Address Setting	
Mode	RGB 3-Ch		DMX Channel / User Mode	
	RGBSeven 3-Ch			
	8bit 7-Ch			
	16bit 14-Ch			
	<b>Master 15-Ch</b>			
	Cells 70-Ch			
	MastCell 78-Ch			
	HSI 4-Ch			
	HSI Mast 10-Ch			
	HSI Cell 38-Ch			
Function	No DMX	<b>Hold</b>	Function if no DMX detected	
		Black		
		Program		
	LCD Set	Display	On / Off	LCD Backlight Shutoff
		Key Lock	On / On1 / Off	LCD Button Key Lock
		Flash	On / Off	Display flashes when no DMX
		Inverse	On / Off	Flips display 180 degrees
	Temp. C/F	F / C		Set temperature display units
	Dim Curve	<b>Standard</b>		Set Dimmer Curve mode
		Stage		
		TV		
		Architec		
		Theatre		
	Stage2			
	Disp Set	ADDR, Disp. Ch		Select default display
	Fan	<b>Auto</b>		Set fan speed
High				
Low				
Cell Order	<b>Standard / Flip</b>		Set Pixel Flip mode (refer to the <b>Pixel Zone</b> section of this manual)	
Gamma	<b>2.0</b>		Set gamma brightness	
	2.2			
	2.4			
	2.8			

CONTINUED ON NEXT PAGE

# SYSTEM MENU (SOFTWARE VER 1.04)

MENU	SUB-MENU	OPTIONS / VALUES		DESCRIPTION
Function (continued)	Frequen	900 Hz, 1000 Hz, 1100 Hz, 1200 Hz, 1300 Hz, 1400 Hz, 1500 Hz, 2500 Hz, 4000 Hz, 5000 Hz, 10 KHz, 15 KHz, 20 KHz, 25 KHz		Set LED refresh frequency
	Network	Universe	001 - 256	Enter fixture universe
		IP	xxx.xxx.xxx.xxx	Enter fixture IP address
		Subnet	xxx.xxx.xxx.xxx	Enter fixture subnet mask
		Protocol	Artnet / Klingnet	Select network protocol
	Net	On / Off		Enable network protocol auto detection
	USB	On / Off		Enable service port for software updates
Defaults	Reset / Cancel		Restore factory settings	
Program	Speed	1 - 99		Set program speed; 1 is slowest and 99 is fastest
	Color	Static	Strobe 000 - 255	Select shutter/strobe value
			R, G, B, RG, GB, RB, RGB, Black	Select static color
		Chang15	Strobe 000 - 255	Select 15 color program + shutter/strobe value
		Chang30	Strobe 000 - 255	Select 30 color program + shutter/strobe value
		Fade	Strobe 000 - 255	Select fade color program + shutter/strobe value
	Macros	0 - 63		Select color macro
Secondary	Off / Secondary		Enable secondary mode	
Info	Time Info	Current	xxxx hours	Fixture run time from power on
		Total	xxxx hours	Fixture total run time
		Last	xxxx hours	Fixture last run time
		Password	Pin = 050	Enter PIN to access clear last menu
		Clear	Off / On	Clear fixture last run time
	Temp Info	xxx F / xxx C		Temperature in fixture head
	Err Info	Error Record 1 ~ Error Record 10		Display last 10 error messages
	Model Inf	SevenBatten72		Display model name
	Software	Vx.xx		Software version
Manual	Strobe	000 - 255		Set DMX values manually
	Dimmer	000 - 255		
	...	...		
	Macro	000 - 255		
Calibrat	Password	050		Enter password to access calibration menu - <b>QUALIFIED TECHNICIANS ONLY!</b>



# SYSTEM MENU (SOFTWARE VER 1.09)

MENU	SUB MENU	OPTIONS / VALUES	DESCRIPTION	
Address	Set ADDR	001 - xxx	DMX Address Setting	
Mode	RGB 3-Ch		DMX Channel / User Mode	
	RGBSeven 3-Ch			
	8bit 7-Ch			
	16bit 14-Ch			
	16b+ Dim 16-Ch			
	<b>Extended 15-Ch</b>			
	Cells 70-Ch			
	Cells Dim7 2-Ch			
	Exte Cells 78-Ch			
	HSI 4-Ch			
	HSI Exten 10-Ch			
	HSI Cell 38-Ch			
Function	No DMX	<b>Hold</b>	Function if no DMX signal detected	
		Black		
		Program		
	LCD Set	Display	On / Off	LCD backlight shutoff
		Key Lock	On / On1 / Off	LCD buttons key lock
		Flash	On / Off	Display flashes when no DMX detected
		Inverse	On / <b>Off</b>	Flips LCD display 180 degrees
	Temp C/F	<b>F / C</b>		Switch temperature units
	Dim Mode	<b>Standard</b>		Set Dimmer Curve Mode
		Stage		
		TV		
		Architec		
		Theatre		
		Stage 2		
		0.0s		
		0.1s		
		0.2s		
0.3s				
0.4s				
0.5s				
0.6s				
0.7s				
0.8s				
0.9s				

CONTINUED ON NEXT PAGE

# SYSTEM MENU (SOFTWARE VER 1.09)

MENU	SUB-MENU	OPTIONS / VALUES	DESCRIPTION
Function (continued)	Dim Mode (con- tinued)	1.0s	Set Dimmer Curve Mode
		1.5s	
		2.0s	
		3.0s	
		4.0s	
		5.0s	
		6.0s	
		7.0s	
		8.0s	
		9.0s	
		10.0s	
	Disp Set	ADDR, Disp Ch	Select default display
	Fan Set	<b>Auto</b>	Set fan speed
		High	
		Low	
	Dim Curve	<b>Linear</b>	Set Dimmer Curve
		Square	
		Inv Square	
		S-Curve	
	Cell Order	<b>Standard</b> / Flip	Set Pixel Flip Mode (refer to the <b>Pixel Zones</b> section of this manual)
	Gamma	<b>2.0</b>	Set gamma brightness
		2.2	
		2.4	
2.8			
Frequen	<b>900 Hz</b> , 1000 Hz, 1100 Hz, 1200 Hz, 1300 Hz, 1400 Hz, 1500 Hz, 2500 Hz, 4000 Hz, 5000 Hz, 10 KHz, 15 KHz, 20 KHz, 25 KHz	Set LED refresh frequency	
Network	Universe	<b>001</b> - 256	Enter fixture universe
	IP	xxx.xxx.xxx.xxx	Enter fixture IP address
	Subnet	xxx.xxx.xxx.xxx	Enter fixture subnet mask
	Protocol	<b>Artnet</b> / Klingnet	Select network protocol
Net	<b>On</b> / Off	Enable network protocol auto detection	
USB	On / <b>Off</b>	Enable service port for software up- dates	
PrimarySW	On / <b>Off</b>	Select primary mode	
Defaults	Reset / <b>Cancel</b>	Restore factory settings	
CONTINUED ON NEXT PAGE			

# SYSTEM MENU (SOFTWARE VER 1.09)

MENU	SUB-MENU	OPTIONS / VALUES		DESCRIPTION
Program	Speed	1 - 99		Set program speed, 1 is slowest and 99 is fastest
	Color	Static	Strobe 000 - <b>255</b>	Select Static color and static/ strobe value
			<b>R, G, B, RG, GB, RB, RGB, Black</b>	
		Chang15	Strobe 000 - <b>255</b>	Select 15 color program + shutter/ strobe value
		Chang30	Strobe 000 - <b>255</b>	Select 30 color program + shutter/ strobe value
	Fade	Strobe 000 - <b>255</b>	Select fade color program + shutter/ strobe value	
	Macros	0 - 63		Select Color Macro
Secondry	<b>Off</b> / Secondry		Enable secondary mode	
Info	Time Info	Current	xxxx Hours	Fixture run time from power on
		Total	xxxx Hours	Fixture total run time
		Last	xxxx Hours	Fixture last run time
		Password	PIN = 050	Enter PIN to access clear last menu
		Clear	<b>Off</b> / On	Clear fixture last run time
	Temp Info	<b>xxx F</b> / xxx C		Temperature in fixture head
	Err Info	Error Record 1 ~ Error Record 10		Display 10 most recent error messages
	Model Inf	SevenBatten72		Display model name
	Software	Vx.xx		Software version
Manual	Strobe	000 - 255		Set DMX values manually
	Dimmer	000 - 255		
	...	...		
	Macro	000 - 255		
Calibrat	Password	050		Enter password to access calibration menu: <b>QUALIFIED TECHNICIANS ONLY!</b>

# PIXEL ZONES

The Flip mode can be selected from the system menu, which flips the starting PIXEL ZONE location and sequence from one end of the batten to the opposite end. This feature makes it easy to configure the pixel zones of multiple battens to be the same regardless of their installation orientation. See diagram below.

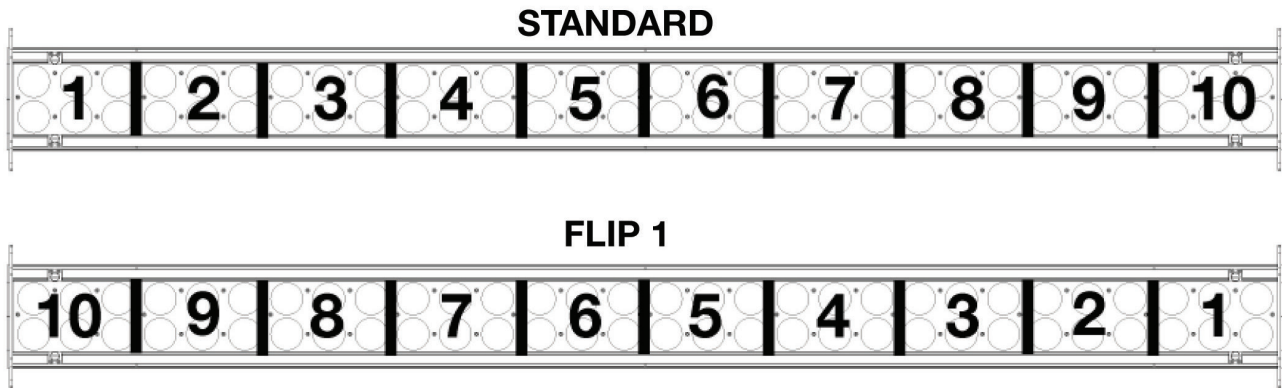

# DMX TRAITS (SOFTWARE VER 1.04)

CHANNEL										DMX VALUES	FUNCTION		
RGB 3CH	RGB Seven 3CH	8bit 7CH	16bit 14CH	Master 15CH	Cells 70CH	Mast Cell 78CH	HSI 4CH	HSI Mast 10CH	HSI Cell 38CH				
				1		1			1		<b>Shutter / Strobe</b>		
												000 - 031	LED Off
												032 - 063	LED On
												064 - 095	Strobe Effect, slow to fast
												096 - 127	LED On
												128 - 159	Strobe Pulse Effect, slow to fast
												160 - 191	LED On
												192 - 223	Random Strobe Effect, slow to fast
												224 - 255	LED On
				2		2	1	2	2	000 - 255	<b>Master Dimmer</b>		
				3		3	2	3	3	000 - 255	<b>Master Dimmer Fine</b>		
				4		4			4		<b>Dimming Mode</b>		
												000 - 020	Standard
												021 - 040	Stage
												041 - 060	TV
												061 - 080	Architectural
												081 - 100	Theater
												101 - 120	Stage 2
												121 - 255	Default to unit setting
				5		5			5		<b>Program Macros</b>		
												000 - 019	No Function
												020 - 039	Program 01
												040 - 059	Program 02
												060 - 079	Program 03
												080 - 099	Program 04
												100 - 119	Program 05
												120 - 139	Program 06
												140 - 159	Program 07
												160 - 179	Program 08
												180 - 199	Program 09
												200 - 219	Program 10
												220 - 239	Program 11
									240 - 255	Program 12			

CONTINUED ON NEXT PAGE

# DMX TRAITS (SOFTWARE VER 1.04)

CHANNEL										DMX VALUES	FUNCTION
RGB 3CH	RGB Seven 3CH	8bit 7CH	16bit 14CH	Master 15CH	Cells 70CH	Mast Cell 78 CH	HSI 4CH	HSI Mast 10CH	HSI Cell 38CH		
				6		6		6	6	000 - 255	<i>Program Macro Speed, slow to fast</i>
				7		7		7	7	000 - 255	<i>Program Macro Fade, slow to fast</i>
											<b>Color Macros</b>
										001 - 004	Color Macro 01
										005 - 008	Color Macro 02
										009 - 012	Color Macro 03
										013 - 016	Color Macro 04
										017 - 020	Color Macro 05
										021 - 024	Color Macro 06
										025 - 028	Color Macro 07
										029 - 032	Color Macro 08
										033 - 036	Color Macro 09
										037 - 040	Color Macro 10
										041 - 044	Color Macro 11
										045 - 048	Color Macro 12
										049 - 052	Color Macro 13
				8		8		8	8	053 - 056	Color Macro 14
										057 - 060	Color Macro 15
										061 - 064	Color Macro 16
										065 - 068	Color Macro 17
										069 - 072	Color Macro 18
										073 - 076	Color Macro 19
										077 - 080	Color Macro 20
										081 - 084	Color Macro 21
										085 - 088	Color Macro 22
										089 - 092	Color Macro 23
										093 - 096	Color Macro 24
										097 - 100	Color Macro 25
										101 - 104	Color Macro 26
										105 - 108	Color Macro 27
										109 - 112	Color Macro 28
										113 - 116	Color Macro 29
										117 - 120	Color Macro 30

CONTINUED ON NEXT PAGE

# DMX TRAITS (SOFTWARE VER 1.04)

CHANNEL										DMX VALUES	FUNCTION
RGB 3CH	RGB Seven 3CH	8Bit 7CH	16Bit 14CH	Master 15CH	Cells 70CH	Mast Cell 78CH	HSI 4CH	HSI Mast 10CH	HSI Cell 38CH		
											<i>Color Macros (continued)</i>
											121 - 124 Color Macro 31
											125 - 128 Color Macro 32
											129 - 132 Color Macro 33
											133 - 136 Color Macro 34
											137 - 140 Color Macro 35
											141 - 144 Color Macro 36
											145 - 148 Color Macro 37
											149 - 152 Color Macro 38
											153 - 156 Color Macro 39
											157 - 160 Color Macro 40
											161 - 164 Color Macro 41
											165 - 168 Color Macro 42
											169 - 172 Color Macro 43
											173 - 176 Color Macro 44
				8		8		8		8	177 - 180 Color Macro 45
											181 - 184 Color Macro 46
											185 - 188 Color Macro 47
											189 - 192 Color Macro 48
											193 - 196 Color Macro 49
											197 - 200 Color Macro 50
											201 - 204 Color Macro 51
											205 - 208 Color Macro 52
											209 - 212 Color Macro 53
											213 - 216 Color Macro 54
											217 - 220 Color Macro 55
											221 - 224 Color Macro 56
											225 - 228 Color Macro 57
											229 - 232 Color Macro 58
											233 - 236 Color Macro 59
											237 - 240 Color Macro 60
											241 - 244 Color Macro 61
											245 - 248 Color Macro 62

CONTINUED ON NEXT PAGE

# DMX TRAITS (SOFTWARE VER 1.04)

CHANNELS										DMX VALUES	FUNCTION
RGB 3CH	RGB Seven 3CH	8Bit 7CH	16Bit 14CH	Master 15CH	Cells 70CH	Mast Cell 78CH	HSI 4CH	HSI Mast 10CH	HSI Cell 38CH		
				8		8		8	8		<b>Color Macros (continued)</b>
										249 - 252	Color Macro 63
										253 - 255	Color Macro 64
							3	9		000 - 255	<b>Hue, All Pixels/Zones, 0% to 100%</b>
							4	10		000 - 255	<b>Saturation, All Pixels/Zones, 0% to 100%</b>
1	1	1	1	9						000 - 255	<b>Red, All Pixels/Zones, 0% to 100%</b>
			2							000 - 255	<b>Red Fine, All Pixels/Zones, 0% to 100%</b>
2	2	2	3	10						000 - 255	<b>Green, All Pixels/Zones, 0% to 100%</b>
			4							000 - 255	<b>Green Fine, All Pixels/Zones, 0% to 100%</b>
3	3	3	5	11						000 - 255	<b>Blue, All Pixels/Zones, 0% to 100%</b>
			6							000 - 255	<b>Blue Fine, All Pixels/Zones, 0% to 100%</b>
		4	7	12						000 - 255	<b>White, All Pixels/Zones, 0% to 100%</b>
			8							000 - 255	<b>White Fine, All Pixels/Zones, 0% to 100%</b>
		5	9	13						000 - 255	<b>Amber, All Pixels/Zones, 0% to 100%</b>
			10							000 - 255	<b>Amber Fine, All Pixels/Zones, 0% to 100%</b>
		6	11	14						000 - 255	<b>Lime, All Pixels/Zones, 0% to 100%</b>
			12							000 - 255	<b>Lime Fine, All Pixels/Zones, 0% to 100%</b>
		7	13	15						000 - 255	<b>UV, All Pixels/Zones, 0% to 100%</b>
			14							000 - 255	<b>UV Fine, All Pixels/Zones, 0% to 100%</b>
									9	000 - 255	<b>Hue, Zone 1, 0% to 100%</b>
									10	000 - 255	<b>Saturation, Zone 1, 0% to 100%</b>

CONTINUED ON NEXT PAGE



# DMX TRAITS (SOFTWARE VER 1.04)

CHANNELS										DMX VALUES	FUNCTION
RGB 3CH	RGB Seven 3CH	8Bit 7CH	16Bit 14CH	Master 15CH	Cells 70CH	Mast Cell 78CH	HSI 4CH	HSI Mast 10CH	HSI Cell 38CH		
									11	000 - 255	<b>Intensity, Zone 1</b> , 0% to 100%
					1	9				000 - 255	<b>Red, Zone 1</b> , 0% to 100%
					2	10				000 - 255	<b>Green, Zone 1</b> , 0% to 100%
					3	11				000 - 255	<b>Blue, Zone 1</b> , 0% to 100%
					4	12				000 - 255	<b>White, Zone 1</b> , 0% to 100%
					5	13				000 - 255	<b>Amber, Zone 1</b> , 0% to 100%
					6	14				000 - 255	<b>Lime, Zone 1</b> , 0% to 100%
					7	15				000 - 255	<b>UV, Zone 1</b> , 0% to 100%
					8	16				000 - 255	<b>Red, Zone 2</b> , 0% to 100%
									12	000 - 255	<b>Hue, Zone 2</b> , 0% to 100%
									13	000 - 255	<b>Saturation, Zone 2</b> , 0% to 100%
									14	000 - 255	<b>Intensity, Zone 2</b> , 0% to 100%
					9	17				000 - 255	<b>Green, Zone 2</b> , 0% to 100%
					10	18				000 - 255	<b>Blue, Zone 2</b> , 0% to 100%
					11	19				000 - 255	<b>White, Zone 2</b> , 0% to 100%
					12	20				000 - 255	<b>Amber, Zone 2</b> , 0% to 100%
					13	21				000 - 255	<b>Lime, Zone 2</b> , 0% to 100%
					14	22				000 - 255	<b>UV, Zone 2</b> , 0% to 100%
									15	000 - 255	<b>Hue, Zone 3</b> , 0% to 100%
									16	000 - 255	<b>Saturation, Zone 3</b> , 0% to 100%
									17	000 - 255	<b>Intensity, Zone 3</b> , 0% to 100%

CONTINUED ON NEXT PAGE

# DMX TRAITS (SOFTWARE VER 1.04)

CHANNELS										DMX VALUES	FUNCTIONS
RGB 3CH	RGB Seven 3CH	8Bit 7CH	16Bit 14CH	Master 15CH	Cells 70CH	Mast Cell 78CH	HSI 4CH	HSI Mast 10CH	HSI Cell 38CH		
					15	23				000 - 255	<b>Red, Zone 3</b> , 0% to 100%
					16	24				000 - 255	<b>Green, Zone 3</b> , 0% to 100%
					17	25				000 - 255	<b>Blue, Zone 3</b> , 0% to 100%
					18	26				000 - 255	<b>White, Zone 3</b> , 0% to 100%
					19	27				000 - 255	<b>Amber, Zone 3</b> , 0% to 100%
					20	28				000 - 255	<b>Lime, Zone 3</b> , 0% to 100%
					21	29				000 - 255	<b>UV, Zone 3</b> , 0% to 100%
									18	000 - 255	<b>Hue, Zone 4</b> , 0% to 100%
									19	000 - 255	<b>Saturation, Zone 4</b> , 0% to 100%
									20	000 - 255	<b>Intensity, Zone 4</b> , 0% to 100%
					22	30				000 - 255	<b>Red, Zone 4</b> , 0% to 100%
					23	31				000 - 255	<b>Green, Zone 4</b> , 0% to 100%
					24	32				000 - 255	<b>Blue, Zone 4</b> , 0% to 100%
					25	33				000 - 255	<b>White, Zone 4</b> , 0% to 100%
					26	34				000 - 255	<b>Amber, Zone 4</b> , 0% to 100%
					27	35				000 - 255	<b>Lime, Zone 4</b> , 0% to 100%
					28	36				000 - 255	<b>UV, Zone 4</b> , 0% to 100%
									21	000 - 255	<b>Hue, Zone 5</b> , 0% to 100%
									22	000 - 255	<b>Saturation, Zone 5</b> , 0% to 100%
									23	000 - 255	<b>Intensity, Zone 5</b> , 0% to 100%
					29	37				000 - 255	<b>Red, Zone 5</b> , 0% to 100%

CONTINUED ON NEXT PAGE

# DMX TRAITS (SOFTWARE VER 1.04)

CHANNELS										DMX VALUES	FUNCTIONS
RGB 3CH	RGB Seven 3CH	8Bit 7CH	16Bit 14CH	Master 15CH	Cells 70CH	Mast Cell 78CH	HSI 4CH	HSI Mast 10CH	HSI Cell 38CH		
					30	38				000 - 255	<b>Green, Zone 5</b> , 0% to 100%
					31	39				000 - 255	<b>Blue, Zone 5</b> , 0% to 100%
					32	40				000 - 255	<b>White, Zone 5</b> , 0% to 100%
					33	41				000 - 255	<b>Amber, Zone 5</b> , 0% to 100%
					34	42				000 - 255	<b>Lime, Zone 5</b> , 0% to 100%
					35	43				000 - 255	<b>UV, Zone 5</b> , 0% to 100%
									24	000 - 255	<b>Hue, Zone 6</b> , 0% to 100%
									25	000 - 255	<b>Saturation, Zone 6</b> , 0% to 100%
									26	000 - 255	<b>Intensity, Zone 6</b> , 0% to 100%
					36	44				000 - 255	<b>Red, Zone 6</b> , 0% to 100%
					37	45				000 - 255	<b>Green, Zone 6</b> , 0% to 100%
					38	46				000 - 255	<b>Blue, Zone 6</b> , 0% to 100%
					39	47				000 - 255	<b>White, Zone 6</b> , 0% to 100%
					40	48				000 - 255	<b>Amber, Zone 6</b> , 0% to 100%
					41	49				000 - 255	<b>Lime, Zone 6</b> , 0% to 100%
					42	50				000 - 255	<b>UV, Zone 6</b> , 0% to 100%
									27	000 - 255	<b>Hue, Zone 7</b> , 0% to 100%
									28	000 - 255	<b>Saturation, Zone 7</b> , 0% to 100%
									29	000 - 255	<b>Intensity, Zone 7</b> , 0% to 100%
					43	51				000 - 255	<b>Red, Zone 7</b> , 0% to 100%
					44	52				000 - 255	<b>Green, Zone 7</b> , 0% to 100%

CONTINUED ON NEXT PAGE

# DMX TRAITS (SOFTWARE VER 1.04)

CHANNELS										DMX VALUES	FUNCTIONS
RGB 3CH	RGB Seven 3CH	8Bit 7CH	16Bit 14CH	Master 15CH	Cells 70CH	Mast Cell 78CH	HSI 4CH	HSI Mast 10CH	HSI Cell 38CH		
					45	53				000 - 255	<b>Blue, Zone 7</b> , 0% to 100%
					46	54				000 - 255	<b>White, Zone 7</b> , 0% to 100%
					47	55				000 - 255	<b>Amber, Zone 7</b> , 0% to 100%
					48	56				000 - 255	<b>Lime, Zone 7</b> , 0% to 100%
					49	57				000 - 255	<b>UV, Zone 7</b> , 0% to 100%
									30	000 - 255	<b>Hue, Zone 8</b> , 0% to 100%
									31	000 - 255	<b>Saturation, Zone 8</b> , 0% to 100%
									32	000 - 255	<b>Intensity, Zone 8</b> , 0% to 100%
					50	58				000 - 255	<b>Red, Zone 8</b> , 0% to 100%
					51	59				000 - 255	<b>Green, Zone 8</b> , 0% to 100%
					52	60				000 - 255	<b>Blue, Zone 8</b> , 0% to 100%
					53	61				000 - 255	<b>White, Zone 8</b> , 0% to 100%
					54	62				000 - 255	<b>Amber, Zone 8</b> , 0% to 100%
					55	63				000 - 255	<b>Lime, Zone 8</b> , 0% to 100%
					56	64				000 - 255	<b>UV, Zone 8</b> , 0% to 100%
									33	000 - 255	<b>Hue, Zone 9</b> , 0% to 100%
									34	000 - 255	<b>Saturation, Zone 9</b> , 0% to 100%
									35	000 - 255	<b>Intensity, Zone 9</b> , 0% to 100%
					57	65				000 - 255	<b>Red, Zone 9</b> , 0% to 100%
					58	66				000 - 255	<b>Green, Zone 9</b> , 0% to 100%
					59	67				000 - 255	<b>Blue, Zone 9</b> , 0% to 100%

CONTINUED ON NEXT PAGE

# DMX TRAITS (SOFTWARE VER 1.04)

CHANNELS										DMX VALUES	FUNCTIONS
RGB 3CH	RGB Seven 3CH	8Bit 7CH	16Bit 14CH	Master 15CH	Cells 70CH	Mast Cell 78CH	HSI 4CH	HSI Mast 10CH	HSI Cell 38 CH		
					60	68				000 - 255	<b>White, Zone 9</b> , 0% to 100%
					61	69				000 - 255	<b>Amber, Zone 9</b> , 0% to 100%
					62	70				000 - 255	<b>Lime, Zone 9</b> , 0% to 100%
					63	71				000 - 255	<b>UV, Zone 9</b> , 0% to 100%
									36	000 - 255	<b>Hue, Zone 10</b> , 0% to 100%
									37	000 - 255	<b>Saturation, Zone 10</b> , 0% to 100%
									38	000 - 255	<b>Intensity, Zone 10</b> , 0% to 100%
					64	72				000 - 255	<b>Red, Zone 10</b> , 0% to 100%
					65	73				000 - 255	<b>Green, Zone 10</b> , 0% to 100%
					66	74				000 - 255	<b>Blue, Zone 10</b> , 0% to 100%
					67	75				000 - 255	<b>White, Zone 10</b> , 0% to 100%
					68	76				000 - 255	<b>Amber, Zone 10</b> , 0% to 100%
					69	77				000 - 255	<b>Lime, Zone 10</b> , 0% to 100%
					70	78				000 - 255	<b>UV, Zone 10</b> , 0% to 100%

**Note:** Pixel/Zone control depends on the flip system menu setting and fixture orientation.

# DMX TRAITS (SOFTWARE VER 1.09, RGB MODES)

CHANNELS									DMX VALUES	FUNCTIONS	Def	Snap
RGB 3CH	RGB Seven 3CH	8Bit 7CH	16Bit 14CH	16Bit + Dim 16CH	Ext 15CH	Cells 70CH	Cells Dim 72CH	Ext Cells 78CH				
					1			1		<b>Strobe</b> 000 - 031 LED Off 032 - 063 LED On 064 - 095 Strobe Effect, slow to fast 096 - 127 LED On 128 - 159 Strobe Pulse Effect in Sequences, slow to fast 160 - 191 LED On 192 - 223 Random Strobe Effect, slow to fast 224 - 255 LED On	050	X
				1	2		1	2	000 - 255	<b>Master Dimmer</b> , 0% to 100%	000	
				2	3		2	3	000 - 255	<b>Master Dimmer Fine</b> , 0% to 100%	000	
					4			4	<b>Dimming Modes</b> 000 - 020 Standard 021 - 040 Stage 041 - 060 TV 061 - 080 Architectural 081 - 100 Theater 101 - 120 Stage 2 <b>Dimmer Delay Time</b> 121 0s 122 0.1s (default) 123 0.2s 124 0.3s 125 0.4s 126 0.5s 127 0.6s 128 0.7s 129 0.8s 130 0.9s 131 1.0s 132 1.5s	000	X	

CONTINUED ON NEXT PAGE

# DMX TRAITS (SOFTWARE VER 1.09, RGB MODES)

CHANNELS									DMX VALUES	FUNCTION	Def	Snap
RGB 3CH	RGB Seven 3CH	8bit 7CH	16Bit 14CH	16bit + Dim 16CH	Ext 15CH	Cells 70CH	Cells Dim 72CH	Ext Cells 78CH				
					4			4		<b>Dimmer Delay Time (continued)</b>	000	X
									133	2.0s		
									134	3.0s		
									135	4.0s		
									136	5.0s		
									137	6.0s		
									138	7.0s		
									139	8.0s		
									140	9.0s		
									141	10s		
									142 - 255	Default		
					5			5		<b>Control</b>		
									000 - 019	Idle		
									020 - 024	Program 1		
									025 - 029	Program 2		
									030 - 034	Program 3		
									035 - 039	Program 4		
									040 - 044	Program 5		
									045 - 049	Program 6		
									050 - 054	Program 7		
									055 - 059	Program 8		
									060 - 064	Program 9		
									065 - 069	Program 10		
									070 - 074	Program 11		
									075 - 079	Program 12		
									080 - 100	Idle		
										<b>Change Refresh Rate (Hz)</b>		
									101 - 105	900		
									106 - 110	1000		
									111 - 115	1100		
									116 - 120	1200 (default)		
									121 - 125	1300		
									126 - 130	1400		

CONTINUED ON NEXT PAGE

# DMX TRAITS (SOFTWARE VER 1.09, RGB MODES)

CHANNELS									DMX VALUES	FUNCTION	Def	Snap
RGB 3CH	RGB Seven 3CH	8Bit 7CH	16Bit 14CH	16B + Dim 16CH	Ext 15CH	Cells 70CH	Cells Dim 72CH	Ext Cells 78CH				
										<b>Change Refresh Rate (Hz) (continued)</b>		
									131 - 135	1500		
									136 - 140	2500		
									141 - 145	4000		
									146 - 150	5000		
									151 - 155	10000		
									156 - 160	15000		
					5			5	161 - 165	20000	000	X
									166 - 170	25000		
									170 - 200	Idle		
										<b>Dimmer Curves</b>		
									201 - 210	Linear		
									211 - 220	Square		
									221 - 230	Inverse Square		
									231 - 240	S-Curve		
									241 - 255	Idle		
					6			6	000 - 255	<b>Program Macro Speed, slow to fast</b>	128	
					7			7	000 - 255	<b>Program Macro Fade, slow to fast</b>	128	
					8			8	000 - 255	<b>Color Macros, 01 to 64</b>	000	X
1	1	1	1	3	9	1	3	9	000 - 255	<b>Red, 0% to 100%</b>	255	
			2	4					000 - 255	<b>Red Fine, 0% to 100%</b>	255	
2	2	2	3	5	10	2	4	10	000 - 255	<b>Green, 0% to 100%</b>	255	
			4	6					000 - 255	<b>Green Fine, 0% to 100%</b>	255	
3	3	3	5	7	11	3	5	11	000 - 255	<b>Blue, 0% to 100%</b>	255	
			6	8					000 - 255	<b>Blue Fine, 0% to 100%</b>	255	
		4	7	9	12	4	6	12	000 - 255	<b>White, 0% to 100%</b>	255	
			8	10					000 - 255	<b>White Fine, 0% to 100%</b>	255	
		5	9	11	13	5	7	13	000 - 255	<b>Amber, 0% to 100%</b>	255	
			10	12					000 - 255	<b>Amber Fine, 0% to 100%</b>	255	
		6	11	13	14	6	8	14	000 - 255	<b>Lime, 0% to 100%</b>	255	

CONTINUED ON NEXT PAGE



# DMX TRAITS (SOFTWARE VER 1.09, RGB MODES)

CHANNELS									DMX VALUES	FUNCTION	Def	Snap
RGB 3CH	RGB Seven 3CH	8Bit 7CH	16Bit 14CH	16Bit + Dim 16CH	Ext 15CH	Cells 70CH	Cells Dim 72CH	Ext Cells 78CH				
			12	14					000 - 255	<b>Lime Fine</b> , 0% to 100%	255	
		7	13	15	15	7	9	15	000 - 255	<b>UV</b> , 0% to 100%	255	
			14	16					000 - 255	<b>UV Fine</b> , 0% to 100%	255	
						8	10	16	000 - 255	<b>Red 2</b> , 0% to 100%	255	
						9	11	17	000 - 255	<b>Green 2</b> , 0% to 100%	255	
						10	12	18	000 - 255	<b>Blue 2</b> , 0% to 100%	255	
						11	13	19	000 - 255	<b>White 2</b> , 0% to 100%	255	
						12	14	20	000 - 255	<b>Amber 2</b> , 0% to 100%	255	
						13	15	21	000 - 255	<b>Lime 2</b> , 0% to 100%	255	
						14	16	22	000 - 255	<b>UV 2</b> , 0% to 100%	255	
						15	17	23	000 - 255	<b>Red 3</b> , 0% to 100%	255	
						16	18	24	000 - 255	<b>Green 3</b> , 0% to 100%	255	
						17	19	25	000 - 255	<b>Blue 3</b> , 0% to 100%	255	
						18	20	26	000 - 255	<b>White 3</b> , 0% to 100%	255	
						19	21	27	000 - 255	<b>Amber 3</b> , 0% to 100%	255	
						20	22	28	000 - 255	<b>Lime 3</b> , 0% to 100%	255	
						21	23	29	000 - 255	<b>UV 3</b> , 0% to 100%	255	
						22	24	30	000 - 255	<b>Red 4</b> , 0% to 100%	255	
						23	25	31	000 - 255	<b>Green 4</b> , 0% to 100%	255	
						24	26	32	000 - 255	<b>Blue 4</b> , 0% to 100%	255	
						25	27	33	000 - 255	<b>White 4</b> , 0% to 100%	255	
						26	28	34	000 - 255	<b>Amber 4</b> , 0% to 100%	255	
						27	29	35	000 - 255	<b>Lime 4</b> , 0% to 100%	255	
						28	30	36	000 - 255	<b>UV 4</b> , 0% to 100%	255	
						29	31	37	000 - 255	<b>Red 5</b> , 0% to 100%	255	
						30	32	38	000 - 255	<b>Green 5</b> , 0% to 100%	255	
						31	33	39	000 - 255	<b>Blue 5</b> , 0% to 100%	255	
						32	34	40	000 - 255	<b>White 5</b> , 0% to 100%	255	
						33	35	41	000 - 255	<b>Amber 5</b> , 0% to 100%	255	
						34	36	42	000 - 255	<b>Lime 5</b> , 0% to 100%	255	
						35	37	43	000 - 255	<b>UV 5</b> , 0% to 100%	255	
						36	38	44	000 - 255	<b>Red 6</b> , 0% to 100%	255	
						37	39	45	000 - 255	<b>Green 6</b> , 0% to 100%	255	

CONTINUED ON NEXT PAGE

# DMX TRAITS (SOFTWARE VER 1.09, RGB MODES)

CHANNELS									DMX VALUES	FUNCTIONS	Def	Snap
RGB 3CH	RGB Seven 3CH	8Bit 7CH	16Bit 14CH	16Bit + Dim 16CH	Ext 15CH	Cells 70CH	Cells Dim 72CH	Ext Cells 78CH				
						38	40	46	000 - 255	<b>Blue 6</b> , 0% to 100%	255	
						39	41	47	000 - 255	<b>White 6</b> , 0% to 100%	255	
						40	42	48	000 - 255	<b>Amber 6</b> , 0% to 100%	255	
						41	43	49	000 - 255	<b>Lime 6</b> , 0% to 100%	255	
						42	44	50	000 - 255	<b>UV 6</b> , 0% to 100%	255	
						43	45	51	000 - 255	<b>Red 7</b> , 0% to 100%	255	
						44	46	52	000 - 255	<b>Green 7</b> , 0% to 100%	255	
						45	47	53	000 - 255	<b>Blue 7</b> , 0% to 100%	255	
						46	48	54	000 - 255	<b>White 7</b> , 0% to 100%	255	
						47	49	55	000 - 255	<b>Amber 7</b> , 0% to 100%	255	
						48	50	56	000 - 255	<b>Lime 7</b> , 0% to 100%	255	
						49	51	57	000 - 255	<b>UV 7</b> , 0% to 100%	255	
						50	52	58	000 - 255	<b>Red 8</b> , 0% to 100%	255	
						51	53	59	000 - 255	<b>Green 8</b> , 0% to 100%	255	
						52	54	60	000 - 255	<b>Blue 8</b> , 0% to 100%	255	
						53	55	61	000 - 255	<b>White 8</b> , 0% to 100%	255	
						54	56	62	000 - 255	<b>Amber 8</b> , 0% to 100%	255	
						55	57	63	000 - 255	<b>Lime 8</b> , 0% to 100%	255	
						56	58	64	000 - 255	<b>UV 8</b> , 0% to 100%	255	
						57	59	65	000 - 255	<b>Red 9</b> , 0% to 100%	255	
						58	60	66	000 - 255	<b>Green 9</b> , 0% to 100%	255	
						59	61	67	000 - 255	<b>Blue 9</b> , 0% to 100%	255	
						60	62	68	000 - 255	<b>White 9</b> , 0% to 100%	255	
						61	63	69	000 - 255	<b>Amber 9</b> , 0% to 100%	255	
						62	64	70	000 - 255	<b>Lime 9</b> , 0% to 100%	255	
						63	65	71	000 - 255	<b>UV 9</b> , 0% to 100%	255	
						64	66	72	000 - 255	<b>Red 10</b> , 0% to 100%	255	
						65	67	73	000 - 255	<b>Green 10</b> , 0% to 100%	255	
						66	68	74	000 - 255	<b>Blue 10</b> , 0% to 100%	255	
						67	69	75	000 - 255	<b>White 10</b> , 0% to 100%	255	
						68	70	76	000 - 255	<b>Amber 10</b> , 0% to 100%	255	
						69	71	77	000 - 255	<b>Lime 10</b> , 0% to 100%	255	
						70	72	78	000 - 255	<b>UV 10</b> , 0% to 100%	255	

# DMX TRAITS (SOFTWARE VER 1.09, HSI MODES)

CHANNELS			DMX VALUES	FUNCTION	Def	Snap
HSI 4CH	HSI Ext 10CH	HSI Cell 38CH				
				<b>Strobe</b>		
			000 - 031	LED Off		
			032 - 063	LED On		
			064 - 095	Strobe Effect, slow to fast		
	1	1	096 - 127	LED On	050	X
			128 - 159	Strobe Pulse Effect in Sequences, slow to fast		
			160 - 191	LED On		
			192 - 223	Random Strobe Effect, slow to fast		
			224 - 255	LED On		
1	2	2	000 - 255	<b>Master Dimmer</b> , 0% to 100%	000	
2	3	3	000 - 255	<b>Dimmer Fine</b> , 0% to 100%	000	
				<b>Dimmer Modes</b>		
			000 - 020	Standard		
			021 - 040	Stage		
			041 - 060	TV		
			061 - 080	Architectural		
			081 - 100	Theater		
			101 - 120	Stage 2		
				<b>Dimmer Delay Time</b>		
			121	0s		
			122	0.1s (default)		
			123	0.2s		
			124	0.3s		
	4	4	125	0.4s	000	X
			126	0.5s		
			127	0.6s		
			128	0.7s		
			129	0.8s		
			130	0.9s		
			131	1.0s		
			132	1.5s		
			133	2.0s		
			134	3.0s		
			135	4.0s		
			136	5.0s		

CONTINUED ON NEXT PAGE

# DMX TRAITS (SOFTWARE VER 1.09, HSI MODES)

CHANNELS			DMX VALUES	FUNCTION	Def	Snap
HSI 4CH	HSI Ext 10CH	HSI Cell 38CH				
	4	4		<b><i>Dimmer Delay Time (continued)</i></b>	000	X
			137	6.0s		
			138	7.0s		
			139	8.0s		
			140	9.0s		
			141	10s		
			142 - 255	Default		
	5	5		<b><i>Control</i></b>	000	X
			000 - 019	Idle		
			020 - 024	Program 1		
			025 - 029	Program 2		
			030 - 034	Program 3		
			035 - 039	Program 4		
			040 - 044	Program 5		
			045 - 049	Program 6		
			050 - 054	Program 7		
			055 - 059	Program 8		
			060 - 064	Program 9		
			065 - 069	Program 10		
			070 - 074	Program 11		
			075 - 079	Program 12		
			080 - 100	Idle		
				<b><i>Change Refresh Rate (Hz)</i></b>		
			101 - 105	900		
			106 - 110	1000		
			111 - 115	1100		
			116 - 120	1200 (default)		
			121 - 125	1300		
			126 - 130	1400		
			131 - 135	1500		
			136 - 140	2500		
			141 - 145	4000		
			146 - 150	5000		
			151 - 155	10000		
156 - 160	15000					
161 - 165	20000					

CONTINUED ON NEXT PAGE

# DMX TRAITS (SOFTWARE VER 1.09, HSI MODES)

CHANNEL			DMX VALUES	FUNCTION	Def	Snap
HSI 4CH	HSI Ext 10CH	HSI Cell 38CH				
				<b>Change Refresh Rate (Hz) (continued)</b>		
			166 - 170	25000		
			170 - 200	Idle		
				<b>Dimmer Curves</b>		
	5	5	201 - 210	Linear (default)	000	X
			211 - 220	Square		
			221 - 230	Inverse Square		
			231 - 240	S-Curve		
			241 - 255	Idle		
	6	6	000 - 255	<b>Program Macro Speed</b> , slow to fast	128	
	7	7	000 - 255	<b>Program Macro Fade</b> , slow to fast	128	
	8	8	000 - 255	<b>Color Macros</b> , 01 to 64	000	X
3	9	9	000 - 255	<b>Hue</b> , 0% to 100%	000	
4	10	10	000 - 255	<b>Saturation</b> , 0% to 100%	255	
		11	000 - 255	<b>Intensity</b> , 0% to 100%	255	
		12	000 - 255	<b>Hue 2</b> , 0% to 100%	000	
		13	000 - 255	<b>Saturation 2</b> , 0% to 100%	255	
		14	000 - 255	<b>Intensity 2</b> , 0% to 100%	255	
		15	000 - 255	<b>Hue 3</b> , 0% to 100%	000	
		16	000 - 255	<b>Saturation 3</b> , 0% to 100%	255	
		17	000 - 255	<b>Intensity 3</b> , 0% to 100%	255	
		18	000 - 255	<b>Hue 4</b> , 0% to 100%	000	
		19	000 - 255	<b>Saturation 4</b> , 0% to 100%	255	
		20	000 - 255	<b>Intensity 4</b> , 0% to 100%	255	
		21	000 - 255	<b>Hue 5</b> , 0% to 100%	000	
		22	000 - 255	<b>Saturation 5</b> , 0% to 100%	255	
		23	000 - 255	<b>Intensity 5</b> , 0% to 100%	255	
		24	000 - 255	<b>Hue 6</b> , 0% to 100%	000	
		25	000 - 255	<b>Saturation 6</b> , 0% to 100%	255	
		26	000 - 255	<b>Intensity 6</b> , 0% to 100%	255	
		27	000 - 255	<b>Hue 7</b> , 0% to 100%	000	
		28	000 - 255	<b>Saturation 7</b> , 0% to 100%	255	
		29	000 - 255	<b>Intensity 7</b> , 0% to 100%	255	
		30	000 - 255	<b>Hue 8</b> , 0% to 100%	000	

CONTINUED ON NEXT PAGE

## DMX TRAITS (SOFTWARE VER 1.09, HSI MODES)

CHANNEL			DMX VALUES	FUNCTION	Def	Snap
HSI 4CH	HSI Ext 10CH	HSI Cell 38CH				
		31	000 - 255	<b>Saturation 8</b> , 0% to 100%	255	
		32	000 - 255	<b>Intensity 8</b> , 0% to 100%	255	
		33	000 - 255	<b>Hue 9</b> , 0% to 100%	000	
		34	000 - 255	<b>Saturation 9</b> , 0% to 100%	255	
		35	000 - 255	<b>Intensity 9</b> , 0% to 100%	255	
		36	000 - 255	<b>Hue 10</b> , 0% to 100%	000	
		37	000 - 255	<b>Saturation 10</b> , 0% to 100%	255	
		38	000 - 255	<b>Intensity 10</b> , 0% to 100%	255	

# SPECIFICATIONS

## SOURCE

60 25W 7-in-1 RGBAW + Lime +UV LEDs

50,000 Hour Average LED Life\*

\*May vary depending on several factors including but not limited to:

Environmental Conditions, Power/Voltage, Usage Patterns (On-Off Cycling), Control, and Dimming.

## EFFECTS

10 Pixel Mapping Zones with Pixel Flip Mode

Special RGB + Channel Mode with Dynamic White, Amber, Lime, UV Added Automatically Smooth

Color Mixing, Internal Programs and 64 Color Macros

High Speed Electronic Shutter and Strobe

16Bit Dimming and Variable Dimming Curve Modes

## CONTROL / CONNECTIONS

12 DMX Channel Modes (78 total channels)

Adjustable Refresh Rate (900-1500, 25,000 Hz)

Adjustable Gamma Brightness (2.0, 2.2, 2.4, 2.8)

4 Button Control Panel / LCD Menu Display

DMX, RDM, Kling-NET, and Art-NET Protocol Support

5pin DMX and RJ45 ethernet In/Out

Power In/Out

## SIZE / WEIGHT

Length: 72.0" (1828.8mm)

Width: 4.5" (114.3mm)

Vertical Height: 9.0" (228.6mm)

Weight: 58.0 lbs. (26.3kg)

## ELECTRICAL / THERMAL

AC 100-240V - 50/60Hz

1000W Max Power Consumption

14°F to 113°F (-10°C to 45°C)

## APPROVALS / RATINGS

CE | IP20

*Specifications and improvements in the design of this unit and this manual are subject to change without any prior written notice.*



**Intertek**  
**4010765**

# DIMENSIONAL DRAWINGS

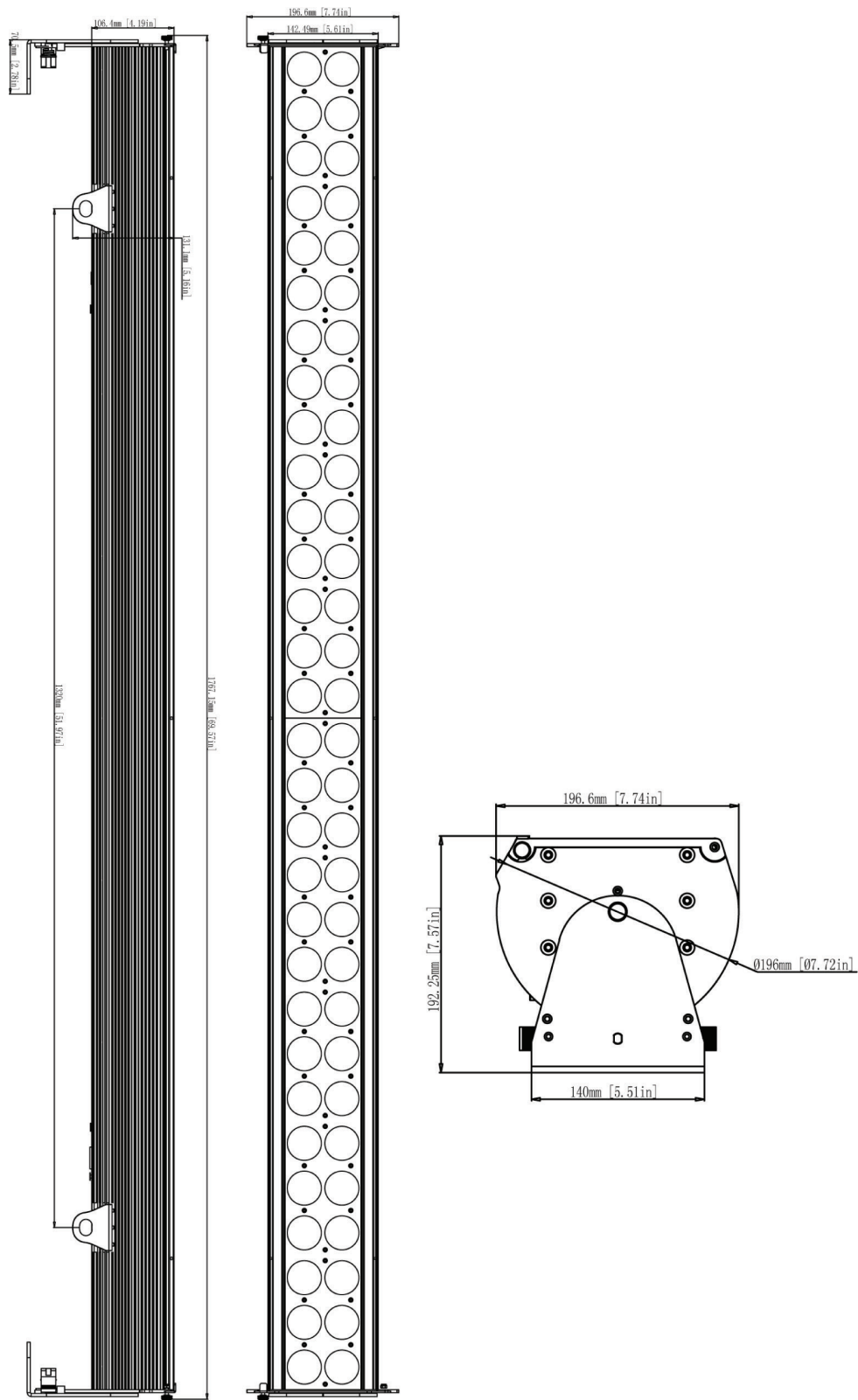

*Specifications and improvements in the design of this unit and this manual are subject to change without any prior written notice.*



## OPTIONAL ACCESSORIES

ORDER CODE	ITEM
TRIGGER CLAMP	Heavy Duty Wrap Around Hook Style Clamp
STR527	5 ft (1.5m) IP65 5-pin DMX Cable
NEU088	3 ft (1m) Power Cable
	Additional Cable Lengths Available

## FCC STATEMENT

This device complies with Part 15 of the FCC Rules. Operation is subject to the following two conditions: (1) this device may not cause harmful interference, and (2) this device must accept any interference received, including interference that may cause undesired operation.

### FCC RADIO FREQUENCY INTERFERENCE WARNINGS & INSTRUCTIONS

This product has been tested and found to comply with the limits as per Part 15 of the FCC Rules. These limits are designed to provide reasonable protection against harmful interference in a residential installation. This device uses and can radiate radio frequency energy and, if not installed and used in accordance with the included instructions, may cause harmful interference to radio communications. However, there is no guarantee that interference will not occur in a particular installation. If this device does cause harmful interference to radio or television reception, which can be determined by turning the device off and on, the user is encouraged to try to correct the interference by one or more of the following methods:

- Reorient or relocate the device.
- Increase the separation between the device and the receiver.
- Connect the device and the radio receiver to electrical outlets on separate electrical circuits.
- Consult the dealer or an experienced radio/TV technician for help.

