

# MAGMATIC

## MAGMA FOG 1500 IP

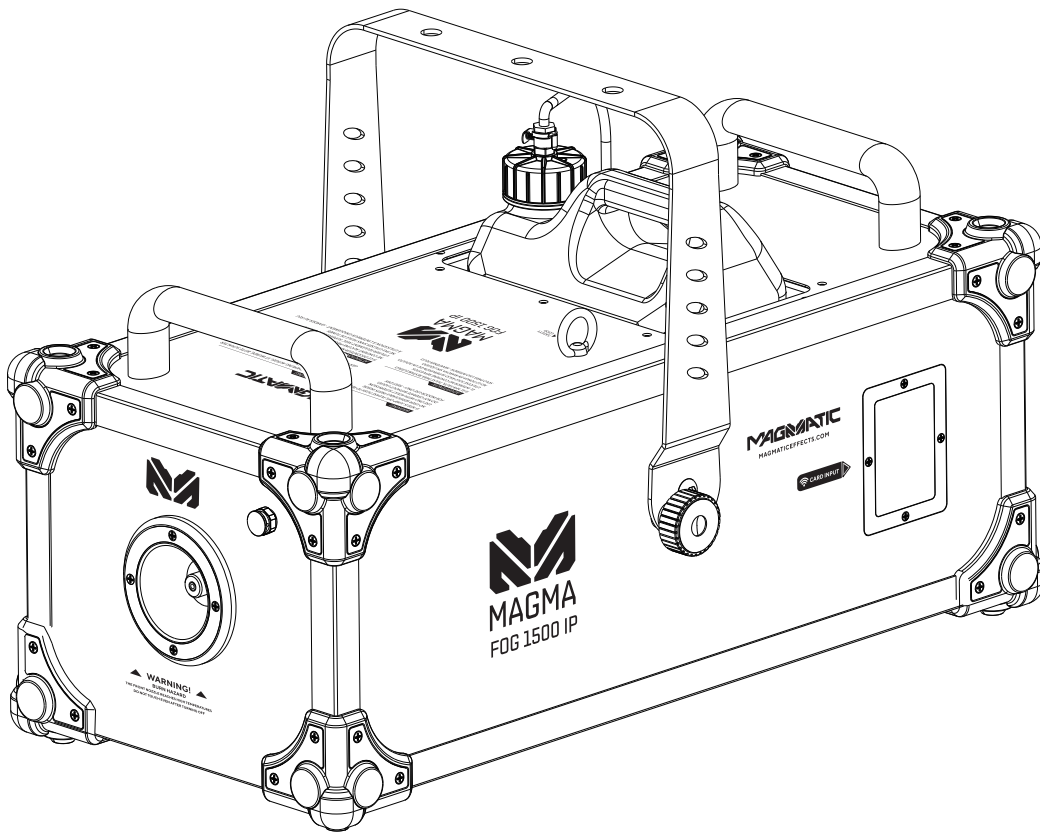

User Manual

©2023 **MAGMATIC EFFECTS** all rights reserved. Information, specifications, diagrams, images, and instructions herein are subject to change without notice. **MAGMATIC EFFECTS** logo and identifying product names and numbers herein are trademarks of **MAGMATIC EFFECTS**. Copyright protection claimed includes all forms and matters of copyrightable materials and information now allowed by statutory or judicial law or hereinafter granted. Product names used in this document may be trademarks or registered trademarks of their respective companies and are hereby acknowledged. All non-MAGMATIC brands and product names are trademarks or registered trademarks of their respective companies.

**MAGMATIC EFFECTS** and all affiliated companies hereby disclaim any and all liabilities for property, equipment, building, and electrical damages, injuries to any persons, and direct or indirect economic loss associated with the use or reliance of any information contained within this document, and/or as a result of the improper, unsafe, insufficient and negligent assembly, installation, rigging, and operation of this product.

**MAGMATIC EFFECTS** | 6122 S. Eastern Ave. | Los Angeles, CA. 90040  
 323-582-3322 | 323-832-9142 fax | [www.elationlighting.com](http://www.elationlighting.com) | [sales@magmaticeffects.com](mailto:sales@magmaticeffects.com)

**Elation Professional B.V.** | Junostraat 2 | 6468 EW Kerkrade, The Netherlands  
 +31 45 546 85 66 | +31 45 546 85 96 fax | [www.elationlighting.eu](http://www.elationlighting.eu) | [info@elationlighting.eu](mailto:info@elationlighting.eu)

**Elation Professional Mexico** | AC Santa Ana 30 | Parque Industrial Lerma, Lerma, Mexico 52000  
 +52 (728) 282-7070



## DOCUMENT VERSION

Due to additional product features and/or enhancements, an updated version of this document may be available online.

Please check [www.elationlighting.com](http://www.elationlighting.com) for the latest revision/update of this manual before beginning installation and/or programming.

Date	Document Version	Software Version	DMX Channel Mode	Notes
07/11/22	1.0	1.0	1 / 2 / 4	Initial Version
04/10/23	1.1	N/C	No Change	Updated Safety Guidelines, Installation, Dimensional Drawings
05/17/23	1.2	N/C	No Change	Updated Specifications, Dimensional Drawings

# CONTENTS

<b>General Information</b>	<b>4</b>
<b>Limited Warranty (USA Only)</b>	<b>5</b>
<b>Warranty Returns (USA Only)</b>	<b>6</b>
<b>IP65 Rated</b>	<b>7</b>
<b>Safety Guidelines</b>	<b>8</b>
<b>Overview</b>	<b>10</b>
<b>Installation</b>	<b>11</b>
<b>Optional Magfly Wireless Card</b>	<b>12</b>
<b>Torque Setting</b>	<b>13</b>
<b>Torque Scew Locations &amp; Specs</b>	<b>14</b>
<b>Setup</b>	<b>15</b>
<b>Control Panel</b>	<b>16</b>
<b>System Menu</b>	<b>17</b>
<b>DMX Channels</b>	<b>20</b>
<b>RDM Parameters</b>	<b>21</b>
<b>Dimensional Drawing</b>	<b>22</b>
<b>Trouble Shooting / Cleaning &amp; Maintenance</b>	<b>23</b>
<b>Specifications</b>	<b>24</b>

# GENERAL INFORMATION

## INTRODUCTION

Please read and understand the instructions in this manual carefully and thoroughly before attempting to operate this device. These instructions contain important safety and use information.

**This product is intended to be used by professionally trained personnel only and is not suitable for private use.**

Every device has been thoroughly tested and has been shipped in perfect operating condition. Carefully check the shipping carton for damage that may have occurred during shipping. If the carton is damaged, carefully inspect the device for damage, and be sure all accessories necessary to install and operate the device have arrived intact. In the event that damage has been found or parts are missing, please contact our customer support team for further instructions. Please do not return this device to your dealer without first contacting customer support. Please do not discard the shipping carton in the trash. Please recycle whenever possible.

## BOX CONTENTS

Power Cable (x1)

## CUSTOMER SUPPORT

Contact **MAGMATIC** customer service for any product related service and support needs. Also visit [forums.elationlighting.com](https://forums.elationlighting.com) with questions, comments, or suggestions.

**ELATION SERVICE USA - Monday - Friday 8:00am to 4:30pm PST**  
323-582-3322 | Fax 323-832-9142 | [sales@magmaticeffects.com](mailto:sales@magmaticeffects.com)

**ELATION SERVICE EUROPE - Monday - Friday 08:30 to 17:00 CET**  
Voice: +31 45 546 85 63 | Fax: +31 45 546 85 96 | [support@elationlighting.eu](mailto:support@elationlighting.eu)

**REPLACEMENT PARTS:** Please visit [parts.elationlighting.com](https://parts.elationlighting.com)



## IMPORTANT NOTICE!

**THERE ARE NO USER SERVICEABLE PARTS INSIDE THIS UNIT. DO NOT ATTEMPT ANY REPAIRS YOURSELF. DOING SO WILL VOID YOUR MANUFACTURER'S WARRANTY. DAMAGES RESULTING FROM MODIFICATIONS TO THIS FIXTURE AND/OR THE DISREGARD OF SAFETY INSTRUCTIONS AND GUIDELINES IN THIS MANUAL VOID THE MANUFACTURER'S WARRANTY AND ARE NOT SUBJECT TO ANY WARRANTY CLAIMS AND/OR REPAIRS.**

**NEVER POINT OR AIM A FOG MACHINE TOWARDS PEOPLE OR THEIR CLOTHING. THIS UNIT EMITS HOT VAPOR AND SHOULD BE USED WITH THE SAME CARE THAT YOU WOULD OBSERVE WHEN USING AN ELECTRIC KETTLE OR IRON.**

## LIMITED WARRANTY (USA ONLY)

- A.** Magmatic Effects hereby warrants, to the original purchaser, Magmatic products to be free of manufacturing defects in material and workmanship for a period of two years (730 days) from the original date of purchase. This warranty excludes discharge lamps and all product accessories. This warranty shall be valid only if the product is purchased within the United States of America, including possessions and territories. It is the owner's responsibility to establish the date and place of purchase by acceptable evidence, at the time service is sought.
- B.** For warranty service, send the product only to the Magmatic Effects factory. All shipping charges must be pre-paid. If the requested repairs or service (including parts replacement) are within the terms of this warranty, Magmatic Effects will pay return shipping charges only to a designated point within the United States. If any product is sent, it must be shipped in its original package and packaging material. No accessories should be shipped with the product. If any accessories are shipped with the product, Magmatic Effects shall have no liability what so ever for loss and/or or damage to any such accessories, nor for the safe return thereof.
- C.** This warranty is void if the product serial number and/or labels are altered or removed; if the product is modified in any manner which Magmatic Effects concludes, after inspection, affects the reliability of the product; if the product has been repaired or serviced by anyone other than the Magmatic Effects factory unless prior written authorization was issued to purchaser by Magmatic Effects; if the product is damaged because not properly maintained as set forth in the product instructions, guidelines and/or user manual.
- D.** This is not a service contract, and this warranty does not include any maintenance, cleaning or periodic check-up. During the periods as specified above, Magmatic Effects will replace defective parts at its expense, and will absorb all expenses for warranty service and repair labor by reason of defects in material or workmanship. The sole responsibility of Magmatic Effects under this warranty shall be limited to the repair of the product, or replacement thereof, including parts, at the sole discretion of Magmatic Effects. All products covered by this warranty were manufactured after January 1, 1990, and bear identifying marks to that effect.
- E.** Magmatic Effects reserves the right to make changes in design and/or performance improvements upon its products without any obligation to include these changes in any products theretofore manufactured.
- F.** No warranty, whether expressed or implied, is given or made with respect to any accessory supplied with the products described above. Except to the extent prohibited by applicable law, all implied warranties made by Magmatic Effects in connection with this product, including warranties of merchantability or fitness, are limited in duration to the warranty periods set forth above. And no warranties, whether expressed or implied, including warranties of merchantability or fitness, shall apply to this product after said periods have expired. The consumer's and/or dealer's sole remedy shall be such repair or replacement as is expressly provided above; and under no circumstances shall Magmatic Effects be liable for any loss and/or damage, direct and/or consequential, arising out of the use of, and/or the inability to use, this product.
- G.** This warranty is the only written warranty applicable to Magmatic Effects products and supersedes all prior warranties and written descriptions of warranty terms and conditions heretofore published.

## **WARRANTY RETURNS (USA ONLY)**

To obtain warranty service, a Return Material Authorization (RMA) number must first be obtained from MAGMATIC. It is the Customer's responsibility to provide product proof of purchase and serial number by acceptable evidence such as an invoice copy or an approved MAGMATIC Extended Warranty Certificate ("EWC") and any relevant maintenance records at the time warranty service is sought. Failure to provide acceptable evidence of product proof of purchase or EWC and any relevant maintenance records may be cause for denial of warranty service.

Products returned for warranty service must be sent without any accessories (i.e., power, data, and safety cables, brackets, clamps, rigging hardware, frost filters, gel frames, barn doors, lenses, hoses, nozzles, rack mounting hardware, etc.), must be boxed using the original and/or suitable packaging materials (double-box and foam) that provides ample product protection for ground and/or air freight transit, and must be shipped freight pre-paid and insured to MAGMATIC in Los Angeles, CA or a MAGMATIC Authorized Service Center. The RMA number must be clearly written on the outside of the return box, and a brief description of the problem and the RMA number must be documented and included in the box.

Products returned for warranty service without an RMA number clearly marked on the outside of the package will be refused and returned to the shipper at the Customer's expense. Products returned for warranty service, which are received damaged due to inadequate and/or improper packaging and/or due to damage caused by the shipping carrier, may incur additional repair charges before warranty service begins and/or may void this warranty. If any product accessories (included and/or optional) are shipped with the product, MAGMATIC and/or the MAGMATIC Authorized Service Center shall have no liability what so ever for the loss and/or damage to any such accessories, nor the safe return thereof. If the requested warranty repairs or service (including parts replacement) are within the terms of this warranty, MAGMATIC will pay return ground transportation shipping charges to a single designated point within the United States.

# IP65 RATED

The **International Protection (IP)** rating system is commonly expressed as “**IP**” (Ingress Protection) followed by two numbers (i.e. IP65), where the numbers define the degree of protection. The first digit (Foreign Bodies Protection) indicates the extent of protection against particles entering the fixture, and the second digit (Water Protection) indicates the extent of protection against water entering the fixture. An **IP65** rated lighting fixture is designed and tested to protect against the ingress of dust (**6**), and low-pressure water jets from any direction (**5**).

**NOTE: THIS FIXTURE IS INTENDED FOR TEMPORARY OUTDOOR USE ONLY!**

**Maritime/Coastal Environment Installations:** A coastal environment is seaside adjacent, and caustic to electronics through exposure to atomized salt-water and humidity, whereas maritime is anywhere within 5-miles of a coastal environment.



**NOT suitable for maritime/coastal environment installations. Installing this fixture in a maritime/coastal environment may cause corrosion and/or excessive wear to the interior and/or exterior components of the fixture. Damages and/or performance issues resulting from installation in a maritime/coastal environment will void the manufacturer’s warranty, and will NOT be subject to any warranty claims and/or repairs.**

Maritime installations require additional preparation, and additional service intervals may be needed given the maritime use. In general, IP ratings presuppose freshwater conditions VS maritime conditions, which are typically more “caustic” to IP fixtures (both internally and externally). A duty-cycle may also be needed when units are not in use. During times of high humidity and colder temperatures, condensation may occur internally so the fixture may require a duty-cycle to bring it up to running temperature, allowing any accumulation of moisture to be expelled via the vent valve. Recommendations can change based on installation environmental circumstances. A waterproof dome or similar device is recommended for use in permanent outdoor installations. When using a dome, refer to manufacturer recommendations for duty-cycle.

**NOTE: NOT ALL FEATURES LISTED ARE AVAILABLE ON ALL FIXTURES; THE FOLLOWING INSTRUCTIONS MAY NOT APPLY. CONTACT SUPPORT FOR ADDITIONAL DETAILS.**

**Exterior Maintenance:** Inspect the exterior every 30-days. The unit must be powered off/disconnected. The chassis should be inspected for any signs of contaminants. Inspect optics to determine if the lens is obstructed, then clean optics and chassis accordingly. Based on initial finding, schedule maintenance accordingly, keeping in mind that exterior maintenance will be required. Even if the luminaires are NOT in use, maintenance will still be needed given its location (exterior use). The use of a durable type of wax on the chassis is recommended since it will help prevent contaminant build up. Inspect both power and data lines for any signs of contaminants or corrosion. Periodically reapplying di-electric grease, especially in coastal environments. If any signs of corrosion/contaminants are present, clean thoroughly, and/or replace connectors, then reapply di-electric grease. Typically, this should be done annually, or any time an opportunity presents itself. As a preventive measure, annual replacement of both vent valves is recommended. The vent valve membrane can become contaminated and/or clogged causing improper venting of humidity within the luminaire. Inspect all mounting hardware as a precaution.

**Interior Maintenance:** Inspect the interior every 30-days. The unit must be powered off/disconnected.

- Inspect zoom/focus mechanism, clean optics, lubricate linear bearings (Krytox oil) as needed, inspect belts for wear
- Inspect all rotating effect wheels, manually rotate them, note any resistance
- Inspect all remaining rotating belts for any wear
- Inspect all fans, clean as needed, check rotation, check connections
- Inspect CMY module, manually move flags and check for signs of resistance, and if needed, clean guide rods first, then reapply a thin layer of grease (moly lube)
- Clean interior with low-volume compressed air, then clean optics prior to reassembly of head covers

Although the base has limited moving parts, the pan belt should also be inspected for wear. Remember to always perform an IP test anytime a cover is removed.

There is no specific time frame regarding the routine replacement of parts such as belts/stepper motors, PCBs, or LEDs. These items should only be replaced on an as needed bases, except for cooling fans, which should be replaced once the luminaries reach 10,000-hours. This is a prophylactic measure intended to keep the unit running as cool as possible, insuring proper function of all internal components. A complete service breakdown is available, please contact [service@elationlighting.com](mailto:service@elationlighting.com) for any needed parts or manuals.

# SAFETY GUIDELINES

This fixture is a sophisticated piece of electronic equipment. To guarantee smooth operation, it is important to follow all instructions and guidelines in this manual. Magmatic Effects is not responsible for injury and/or damages resulting from the misuse of this fixture due to the disregard of the information printed in this manual. Only qualified and/or certified personnel should perform installation of this fixture and only the original rigging parts included with this fixture should be used for installation. Any modifications to the fixture and/or the included mounting hardware will void the original manufacturer's warranty and increase the risk of damage and/or personal injury.



**PROTECTION CLASS 1 - FIXTURE MUST BE PROPERLY GROUNDED.**



**THERE ARE NO USER SERVICEABLE PARTS INSIDE THIS UNIT. DO NOT ATTEMPT ANY REPAIRS YOURSELF. DOING SO WILL VOID YOUR MANUFACTURER'S WARRANTY. DAMAGES RESULTING FROM MODIFICATIONS TO THIS DEVICE AND/OR THE DISREGARD OF SAFETY INSTRUCTIONS AND GUIDELINES IN THIS MANUAL VOID THE MANUFACTURER'S WARRANTY AND ARE NOT SUBJECT TO ANY WARRANTY CLAIMS AND/OR REPAIRS.**



**DO NOT PLUG THIS UNIT INTO A DIMMER PACK  
DO NOT REMOVE THE COVER UNDER ANY CONDITIONS  
KEEP UNIT IN AN UPRIGHT POSITION  
NEVER OPERATE THIS UNIT WITH THE COVER REMOVED  
UNPLUG FROM POWER DURING LONG PERIODS OF NON-USE  
ENSURE TANK IS EMPTY BEFORE STORAGE OR TRANSPORT  
DO NOT MOVE WHEN FILLED WITH FLUID  
DISCONNECT POWER BEFORE ADDING FLUID OR PERFORMING MAINTENANCE  
DO NOT TILT THE MACHINE MORE THAN 30 DEGREES WHILE IN USE**

**IP65**

**FIXTURE IS COMPLETELY DUST TIGHT AND PROTECTED AGAINST LOW PRESSURE WATER JETS FROM ANY DIRECTION  
PORTS MUST BE SEALED WHEN NOT IN USE TO MAINTAIN IP RATING!**



# SAFETY GUIDELINES

- **CAUTION: Fog machines may set off smoke alarms!**
- Do not attempt installation and/or operation of this device without proper knowledge of how to do so.
- Do not point or direct fog output in an unsafe direction.
- Do not touch the front nozzle while the machine is in operation, or immediately after the device has been shut down, as the nozzle will be hot during operation.
- Do not shake device, and avoid brute force when installing and/or operating.
- Be sure to save the packing carton in the unlikely event the device may have to be returned for service.
- Be sure that the local power outlet matches the required voltage for the device.
- Do not remove components or disassemble the device. There are no user-serviceable parts inside.
- Never connect this device to a dimmer pack.
- Do not attempt to operate this device if it has been damaged in any way.
- Never use this device with the cover removed.
- Do not attempt to operate this device if the power cord has been frayed, crimped, and/or damaged. Replace any damaged power cords with new cords of the same power rating.
- Do not remove or break off the ground prong from the electrical cord. This prong is used to reduce the risk of electrical shock and fire in case of an internal short.
- Always disconnect from main power before making any connection, performing cleaning or maintenance, or adding or draining fluid.
- Always drain fluid before moving the device.
- Always be sure to mount this device in an area that will allow proper ventilation.
- Always disconnect power cords during long periods of non-use.
- Always mount this unit in a safe and stable manner.
- Please route your power cord out of the way of foot traffic. Power cords should be routed so they are not likely to be walked on, or pinched by items placed upon or against them.
- The device should be serviced by qualified service personnel when:
  - The power cords or plugs have become damaged.
  - Objects have fallen on the unit causing damage to the outer casing.
  - The device does not operate normally or exhibits a marked change in performance.

# OVERVIEW

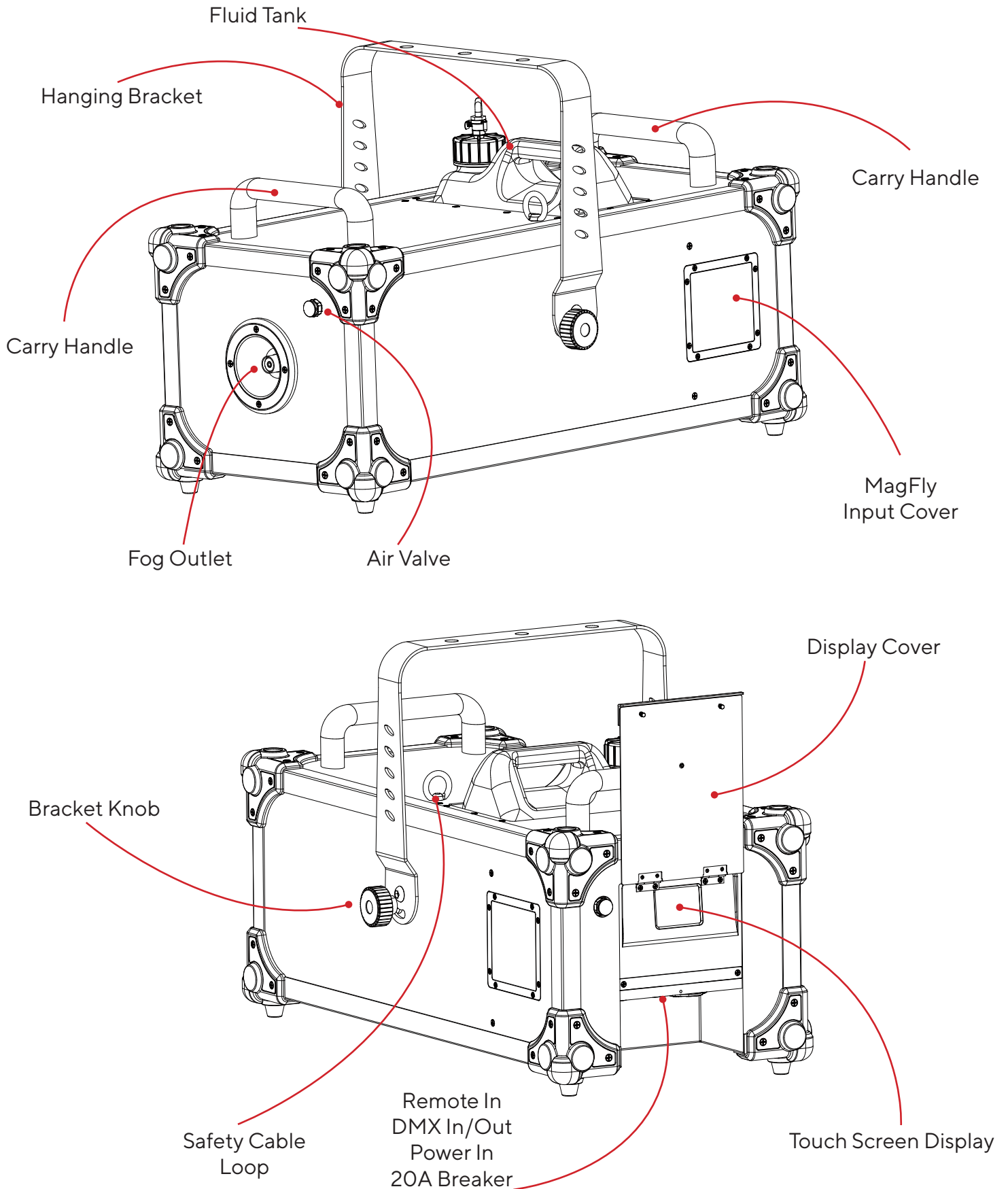

# INSTALLATION

## CLAMP INSTALLATION

This unit features a mounting yoke with integrated clamp attachment points, as well as a safety cable loop located near the fluid tank (see the illustration below). When mounting this fixture to truss, be sure to secure appropriately rated clamps (not included) to the mounting yoke, and attach a separate **SAFETY CABLE** of the appropriate rating to the safety cable loop. Please note that at least two mounting clamps are required to securely install this device in a suspended environment.

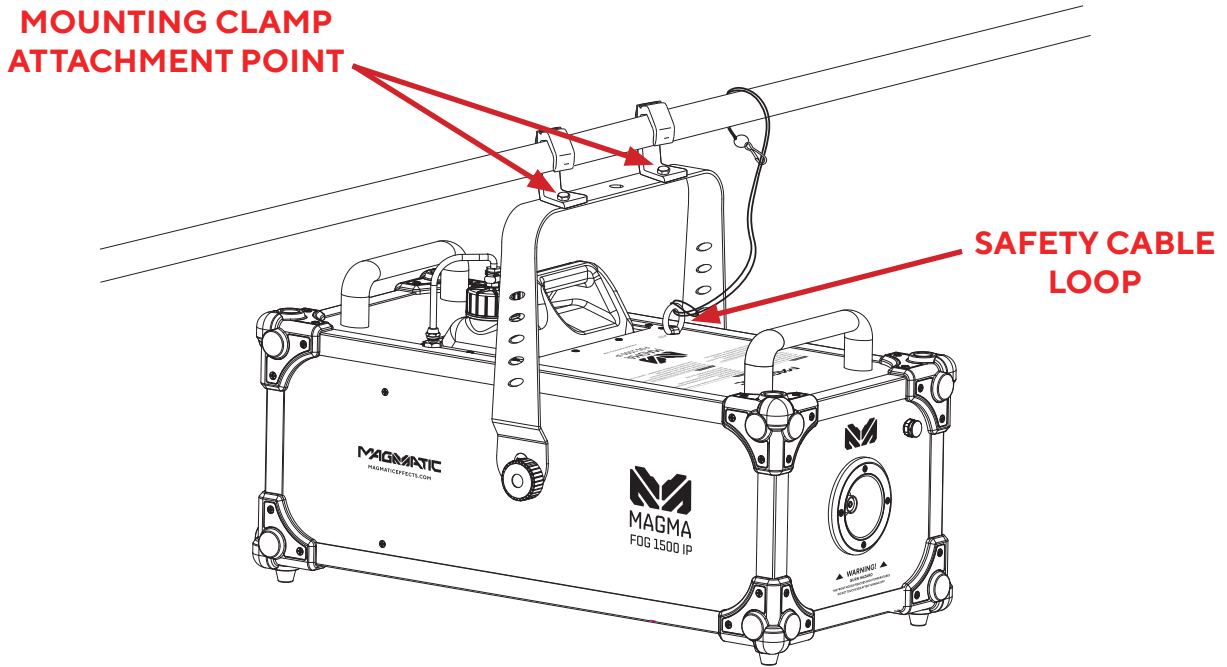

**SAFETY CABLE**

**ALWAYS ATTACH A SAFETY CABLE WHEN INSTALLING THIS UNIT IN A SUSPENDED ENVIRONMENT TO ENSURE THAT THE UNIT WILL NOT FALL IN THE EVENT THAT THE CLAMP FAILS.**

## RIGGING

Overhead rigging requires extensive experience, including but not limited to: calculating working load limits, understanding the installation material being used, and periodic safety inspection of all installation material and the device. If you lack these qualifications, do not attempt the installation yourself. Improper installation can result in bodily injury.

# INSTALLATION

## OPTIONAL MAGFLY WIRELESS CARD

The Magma Fog 1500 IP features 2 card slots for optional MagFly wireless receiving cards. These card slots are located behind the the MagFly input cover. For ordering information, see **ACCESSORIES** section on page 23.

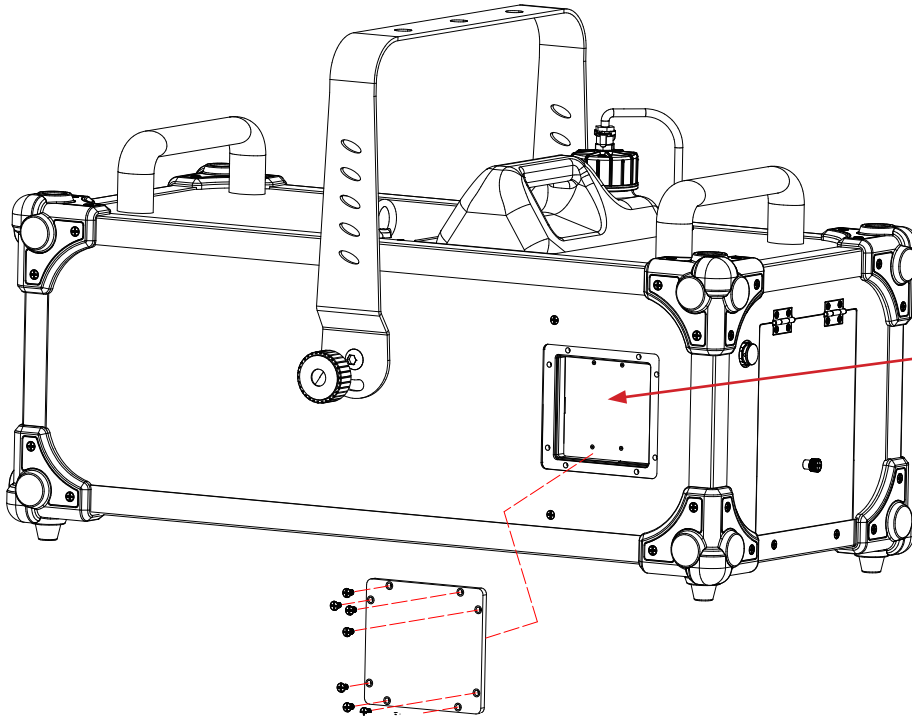

**1.** Locate the MagFly input cover, and remove all (8) screws with a phillips screw driver.

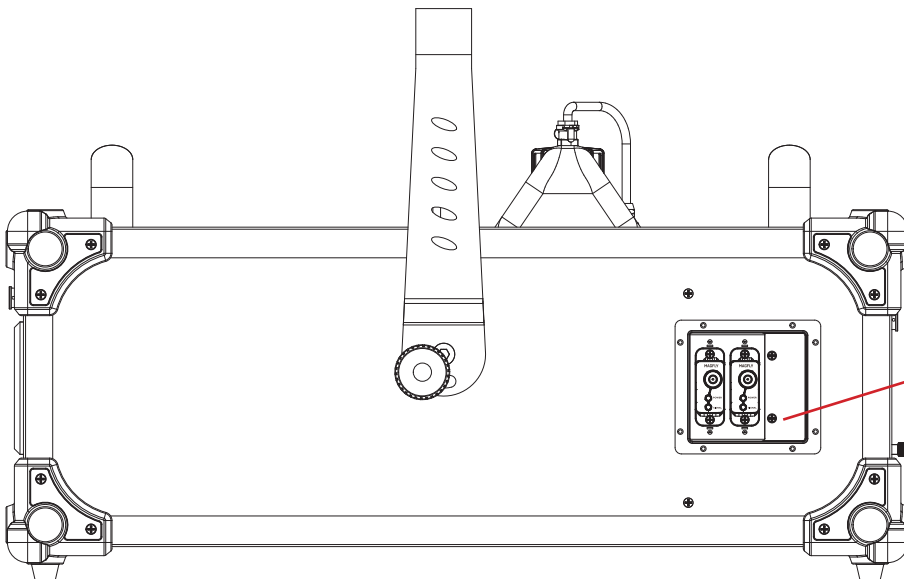

**2.** Insert up to (2) MagFly receiving cards into the card slots, and press firmly into place. Once the cards are in place, replace the input cover and re-install the screws to fasten the cover in place (see torque settings chapter for correct torque setting specs)

# TORQUE SETTINGS

TORQUE DRIVERS (Recommended): UTICA TS-30 (Shown)

TORQUE DRIVER (Alternate):

- Proto J6107A
- Wiha 28887



**CAUTION! DO NOT OVER TORQUE SCREWS AS THIS CAN CAUSE LEAKAGE ISSUES! TO CONFIRM THE IP65 INTEGRITY AFTER DISASSEMBLY, TEST THE FIXTURE USING THE IP TESTER. CONTACT SERVICE SERVICE FOR MORE DETAILS.**



**CAUTION! THE USE OF PROTECTIVE GLOVES AND SAFETY GOGGLES IS STRONGLY RECOMMENDED WHILE PERFORMING THE IP PRESSURE TEST! AVOID PLACING YOUR FACE, EYES, HANDS, ETC IN CLOSE PROXIMITY TO THE FIXTURE WHILE PERFORMING THIS TEST!**



<b>IP PRESSURE TESTING PARAMETERS</b>		
<b>Low Pressure Limit</b>	<b>High Pressure Limit</b>	<b>Steady/Hold Time</b>
3.04PSI 21kPa	4.49PSI 31kPa	30 seconds

# TORQUE SCREW LOCATIONS & SPECS

**ALL SCREWS MUST BE TIGHTENED WITH A TORQUE DRIVER.** Please refer to the drawing below for screw locations, quantity, and torque settings.

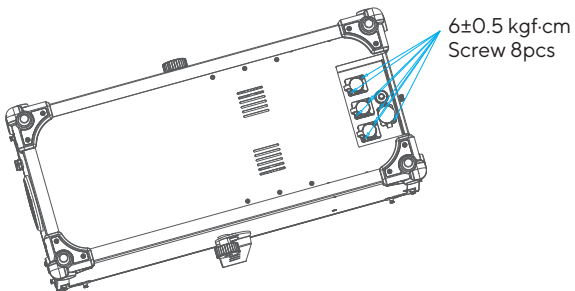
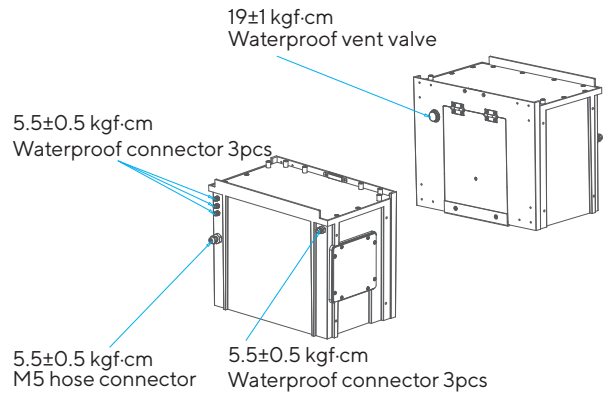
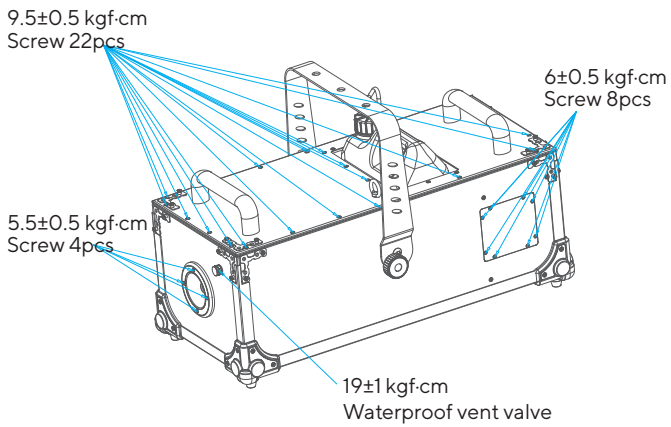
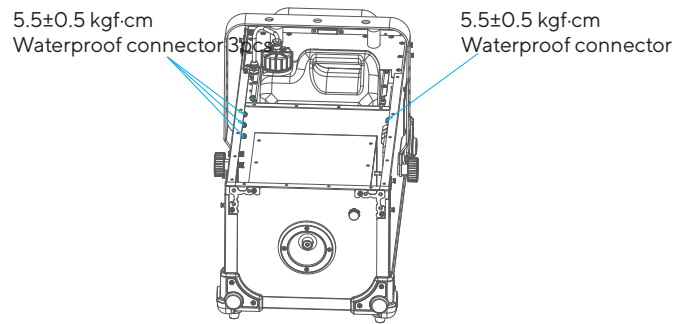
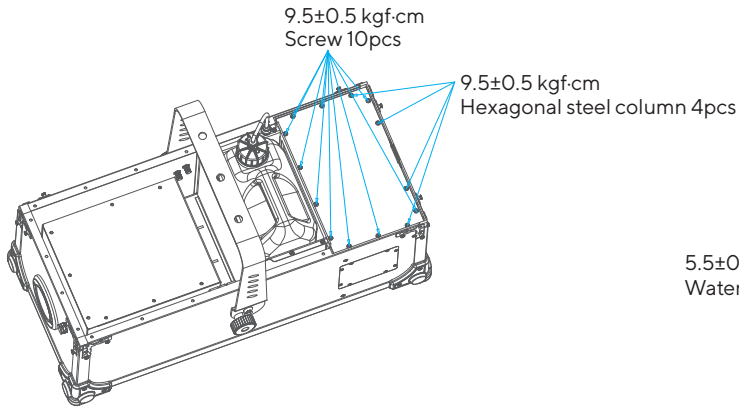

# SET UP

1. Open the shipping carton and carefully remove the unit.
2. Be sure to remove ALL the packing material, paying particular attention to the area around the fog outlet vent.
3. Set the unit on a flat dry surface.
4. Unscrew the tank cap and fill the reservoir with **Atmosity Extreme Filtered Fog Fluid** (AEF-2L, AEF-4L, AEF-20L). Never run the unit on anything other than approved, **MAGMATIC** branded fluid, as doing so can result in severe damage to your device.
5. Screw the tank cap back onto the fluid tank. Be careful not to pinch, twist, or tangle the feed tube connected to the tank cap.
6. Connect the included power cable to the back of the unit (located underneath the touch-screen display) and connect the the unit to a properly rated power source. Allow the unit to warm up for at least fourteen (14) minutes before beginning fog emission.

# CONTROL PANEL



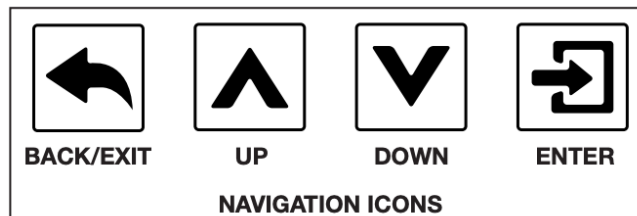
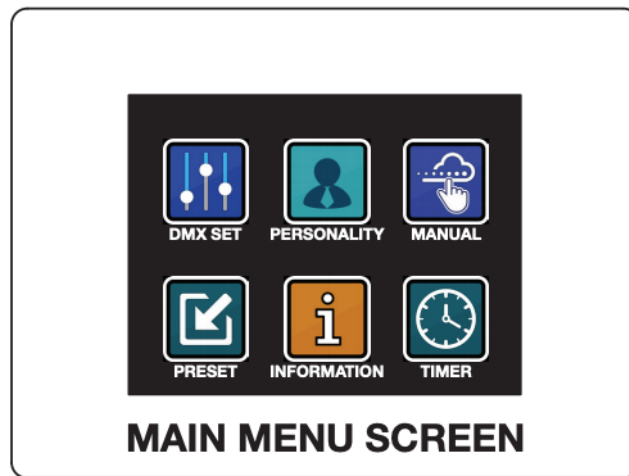

This fixture includes a system menu with an easy to navigate touch screen control panel where all necessary settings and adjustments are made. When first powering on the fixture, the fixture's main menu will be displayed (**see Main Menu Screen below**).

Press the main menu icon you would like to access. Use the **ENTER** button to access sub menus and use the **UP** and **DOWN** buttons to make adjustments. Press the **ENTER** button to confirm your adjustments. You may exit the main menu at any time without making any adjustments by pressing the **BACK/EXIT** button.











# SYSTEM MENU

	<b>DMX SET</b>	DMX Addr	1 - 512		DMX Addressing
		DMX Mode	1-ch		DMX Channel Mode Selection
			2-ch		
4-ch					
	<b>PERSONALITY</b>	MagApp Set	MagApp Name	0-XXXX	Displays MagApp Name
			MagApp Passcode	00000000 - 00009999	MagApp Password
			MagApp IP	0-255.0	Display IP Address
			MagApp Port	0-65535	Network Port
			MagApp Reset	Complete	Network connection reset
				Failed, try again	
	MagApp -> DMX & Magfly	On/Off	Magfly Transmit On		
	LCD Set	Screen OFF: Never/10s/40s/1min/2min/5min/10min/20min		Display Blackout Time	
	Magfly Set	Magfly Channel 0-14		Magfly Channel Setting	
		Magfly: On/Off		Magfly Activation	
	No Fluid	On/Off		Activate/Deactivate No Fluid Warning	
	MagRF Learn	Will notify whether MagRF connection is successful after 20s			
Last State	Yes/No		Activate/Deactivate last state		
Default	Press "ENTER"		Restore Factory Settings		
	<b>MANUAL</b>	Fog	1%-100 (Output is continuous at 20% or lower)		Manual Control
	<b>TIMER</b>	Fog	1%-100% (Output is continuous at 20% or lower)		Fog Output
		Duration	0-250s		Duration Setting
		Interval	0-2500s		Interval Setting
continued on next page					

# SYSTEM MENU

	<b>PRESET</b>	Preset 1: 10s Duration, Fog 100%, 4s Interval		Preset Setting 1 (not adjustable)
		Preset 2: 30s Duration, Fog 80%, 10s Interval		Preset Setting 2 (not adjustable)
		Preset 3: 60s Duration, Fog 60%, 30s Interval		Preset Setting 3 (not adjustable)
		Preset 4: 150s Duration, Fog 40%, 120s Interval		Preset Setting 4 (not adjustable)
		Preset 5: 200s Duration, Fog 30%, 200s Interval		Preset Setting 4 (not adjustable)
	<b>INFORMATION</b>	State	Normal / Error	Machine Status
		Slot 1	Null / MagFly / MagApp / MagRF	Slot 1 Status
		Slot 2	Null / MagFly / MagApp / MagRF	Slot 2 Status
		Last Control	LCD_auto/LCD_manual/DMX/ MagApp/MagRF/MagRemote/Error	Current Control Status
		MagRemote State	YES/NO	Remote Control Status
		MagApp Connect	Null/Phone/Route/No	Wifi Connection Status
		MagApp IP	NO / 0~255,0~255,0~255,0~255	Current Wifi IP Status
		MagFly CH.	0-14	Current Magfly Channel Setting
		DMX Addr.	1-512	Current DMX Address
		DMX Mode	1 or 2 or 4	Current DMX Ch. Mode
		Timer Output	0% ~100%	Current Timer Output
		Timer Int.	0-2500s	Current Timer Interval
		Timer Dur.	0-250s	Current Timer Duration
		Heating	0%~100%	Heater Progress
		No Fluid	Normal / Empty	Current Fluid Status
		Heater State	Normal / Error/No Heat	Current Heater Status
		LCD Ver.	VX.X	Display Version
Sftwr Ver.	VX.X	Software Version		

# MESSAGE ICONS

Icon	Description
	Icon appears when MagFly module is connected. 4-bar symbol on the right indicates signal strength, with 0 bars being weakest and 4 bars being strongest.
	Icon appears when MagApp module is connected. 4-bar symbol on the right indicates signal strength, with 0 bars being weakest and 4 bars being strongest.
	Icon appears when MagRF module is connected. Note that the icon will only appear if an RF signal exists.
	Icon appears when MagRemote is connected.
	Icon indicates that the fluid tank is empty, and disappears when fluid is added to the tank.

# DMX CHANNEL FUNCTIONS & VALUES

MAGMATIC MAGMA FOG 1500 IP: DMX TRAITS				
1-CH	2-CH	4-CH	VALUES	FUNCTION
				<b>FOG</b>
	1	1	000-005	OFF
			006-255	ON
				<b>VOLUME</b>
1	2	2	0-255	1%-100% (Output is continuous at 20% or lower)
				<b>DURATION</b>
		3	000-005	0s
			006-255	1s-250s
				<b>INTERVAL</b>
		4	000-005	0s
			006-255	10S-2500s

# RDM PARAMETERS

NOTE: In order for RDM to work properly, RDM enabled equipment must be used throughout the entire system, including DMX data splitters and wireless systems.

Remote Device Management (RDM) is a protocol that sits on top of the DMX512 data standard for lighting, and allows the DMX systems of the fixtures to be modified and monitored remotely. This protocol is ideal for instances in which a unit is installed in a location that is not easily accessible.

With RDM, the DMX512 system becomes bi-directional, allowing a compatible RDM enabled controller to send out a signal to devices on the wire, as well as allowing the fixture to respond (known as a GET command). The controller can then use its SET command to modify settings that would typically have to be changed or viewed directly via the unit's display screen, including the DMX Address, DMX Channel Mode, and Temperature Sensors.

## FIXTURE RDM INFORMATION:

Device Model ID	RDM Code	Personality ID
1110	22A6H	1 (1) 2 (2) 4 (3)

Please be aware that **not all RDM devices support all RDM features**, and therefore it is important to check beforehand to ensure that the equipment that you are considering includes all of the features that you require.

The following parameters are accessible in RDM on this device:

[0x1000] IDENTIFY_DEVICE
[0x00F0] DMX_START_ADDRESS
[0x00C0] SOFTWARE_VERSION_LABEL
[0x0060] DEVICE_INFO
[0x0080] DEVICE_MODEL_DESCRIPTION
[0x0081] MANUFACTURER_LABEL
[0x0082] DEVICE_LABEL
[0x0050] SUPPORTED_PARAMETERS
[0x00E1] DMX_PERSONALITY_DESCRIPTION
[0x00E0] DMX_PERSONALITY
[0x0200] SENSOR_DEFINITION
[0x0201] SENSOR_VALUE

# DIMENSIONAL DRAWINGS

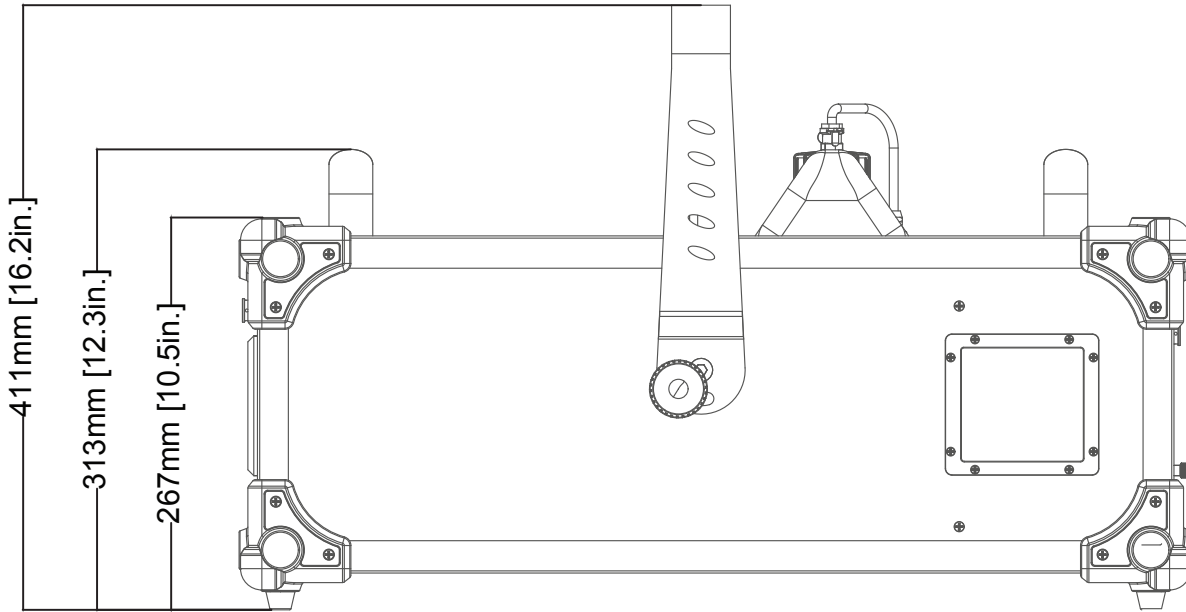
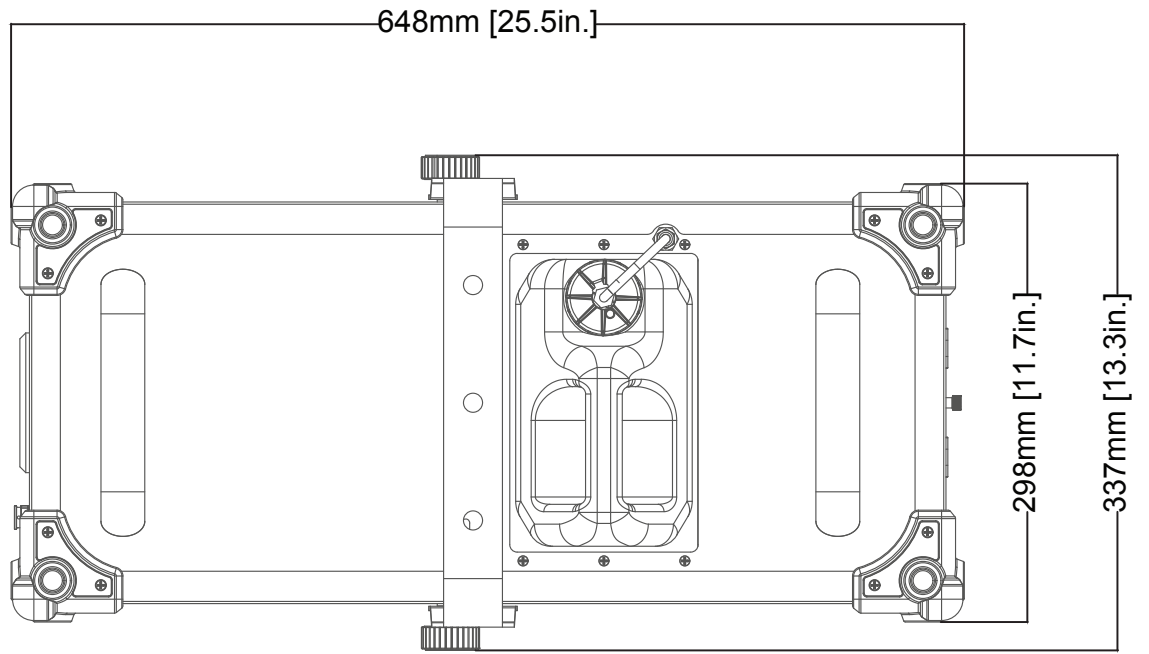

## TROUBLE SHOOTING

If you experience low output, pump noise, or no output at all, disconnect the device and discontinue use immediately. Do not attempt to continue operation as this may damage the machine. Check the fluid level, the breaker, and the wall outlet to make sure that it is sending power. If all the above factors do not appear to be causing the issue, and the unit still fails to operate correctly, the unit will require service. **Please contact Magmatic Effects for assistance (contact information on page 4).**

## CLEANING & MAINTENANCE

When storing your device, be sure to store in a cool area. Cover the device so that dust does not build up on the device. When storing for long periods of time it is highly advisable to run the device at least once every 3-4 months. Long periods of inactivity can severely shorten the life of your device. **Only run Magmatic's Atmosity Extreme Filtered fog fluid through your machine.** Never run plain water, vinegar, or any other liquid solution through your device, as doing so will severely damage your device.

# SPECIFICATIONS

## PERFORMANCE

Rated Power: 1500W  
Max Output: 60,000 CFM\* (cu ft/min.)  
Ready Time: Initial = 14 Minutes\*  
Fluid Capacity: 1.32 gallons (5 liters)  
Fluid Consumption: 6.76 oz/min (200 ml/min)  
\*approximate

## COMPATIBLE FLUID

Atmosity Extreme Filtered Fog Fluid (AEF-2L, AEF-4L, AEF-20L)

## CONSTRUCTION

Thermally Protected Heat Exchanger  
Rugged Case Design  
Convenient Carry Handles

## CONTROL

3 DMX Channel Modes (1 / 2 / 4)  
Onboard LCD Touch Control Panel  
DMX-512 and RDM Protocol Support  
Optional MAGFLY Wireless DMX Transceiver  
Optional MAGRF Wireless and MAGREMOTE Wired Remotes

## CONNECTIONS

Locking 5pin XLR Connector, DMX In/Out  
IP65 Locking Power Connector In  
With Wired Digital Communication Network

## SIZE / WEIGHT

Length: 25.5 in. (648mm)  
Width: 13.3 in. (337mm)  
Height: 16.2 in. (411mm)  
Weight: 61.3 lbs. (27.8kg)

## ELECTRICAL

AC120V 60Hz (US Version)  
AC230V 50Hz (EU Version)  
20A @ 120VAC(NFB)  
10A @ 230VAC - 240VAC  
Max Power Consumption: 1600W

## THERMAL

Maximum Ambient Temperature (Ta max) 104°F (40°C)  
Exterior Surface Temperature, Steady State: 149°F (65°C)

## ACCESSORIES

MagFLY (MSR934) Wireless DMX Transceiver Module  
MagRF (MSR912) RF Module and Wireless Remote

## APPROVALS / RATINGS

CE | IP65

**Specifications are subject to change without notice.**



This page intentionally left blank.

