

CW PROFILE HP™

user manual

©2019 ELATION PROFESSIONAL all rights reserved. Information, specifications, diagrams, images, and instructions herein are subject to change without notice. ELATION PROFESSIONAL logo and identifying product names and numbers herein are trademarks of ELATION PROFESSIONAL. Copyright protection claimed includes all forms and matters of copyrightable materials and information now allowed by statutory or judicial law or hereinafter granted. Product names used in this document may be trademarks or registered trademarks of their respective companies and are hereby acknowledged. All non-ELATION brands and product names are trademarks or registered trademarks of their respective companies.

ELATION PROFESSIONAL and all affiliated companies hereby disclaim any and all liabilities for property, equipment, building, and electrical damages, injuries to any persons, and direct or indirect economic loss associated with the use or reliance of any information contained within this document, and/or as a result of the improper, unsafe, insufficient and negligent assembly, installation, rigging, and operation of this product.

ELATION PROFESSIONAL USA

6122 S. Eastern Ave. Los Angeles, CA. 90040
 323-582-3322 | Fax 323-832-9142 | www.elationlighting.com | sales@elationlighting.com

ELATION PROFESSIONAL B.V.

Junostraat 2 | 6468 EW Kerkrade, The Netherlands
 +31 45 546 85 66 | Fax +31 45 546 85 96 | www.elationlighting.eu | info@elationlighting.eu

ELATION PROFESSIONAL Mexico

AV Santa Ana 30 Parque Industrial Lerma, Lerma, Mexico 52000
 +52 (728) 282-7070 | ventas@adj.com

D O C U M E N T V E R S I O N



Due to additional product features and/or enhancements, an updated version of this document may be available online. Please scan the QR Code with your mobile device or visit www.elationlighting.com for the latest revision/update of this manual, before installation and/or programming.

Date	Document Version	Software Version ≥	DMX Channel Modes	Notes
08/25/17	1	1.1.1A	1 / 4	Initial release.
10/18/18	2	1.1.2	NO CHANGE	Updated System Menu.
12/11/18	2.2	N/C	NO CHANGE	Updated manual format.
09/12/19	2.4	1.1.6	NO CHANGE	Updated System Menu.
12/01/20	2.6	1.1.7	NO CHANGE	Updated primary/secondary modes

CONTENTS

General Information	4
Warranty Returns (USA Only)	5
Safety Guidelines	6
Maintenance Guidelines	7
Fixture Overview	8
Lens and Gobo Holder Installation	9
Fixture Installation	10
System Menu	12
DMX Channel Functions And Values	19
Specifications	20
Optional Accessories	23

GENERAL INFORMATION

INTRODUCTION

This fixture has been designed to perform reliably for years when the guidelines in this booklet are followed. Please read and understand the instructions in this manual carefully and thoroughly before attempting to operate this unit. These instructions contain important information regarding safety during use and maintenance.

UNPACKING

Every fixture has been thoroughly tested and has been shipped in perfect operating condition. Carefully check the shipping carton for damage that may have occurred during shipping. If the carton appears to be damaged, carefully inspect your unit for damage and be sure all accessories necessary to operate the unit have arrived intact. In the event damage has been found or parts are missing, please contact our customer support team for further instructions. Please do not return this unit to your dealer without first contacting customer support at the number listed below. Please do not discard the shipping carton in the trash. Please recycle whenever possible.

BOX CONTENTS

Power Cable

NOTE: Lens Not Included Sold Separately

CUSTOMER SUPPORT

Contact **ELATION Service** for any product related service and support needs. Also visit forums.elationlighting.com with questions, comments or suggestions.

ELATION SERVICE USA - Monday - Friday 8:00am to 4:30pm PST
323-582-3322 | Fax 323-832-9142 | support@elationlighting.com

ELATION SERVICE EUROPE - Monday - Friday 08:30 to 17:00 CET
+31 45 546 85 63 | Fax +31 45 546 85 96 | support@elationlighting.eu

REPLACEMENT PARTS please visit parts.elationlighting.com

WARRANTY RETURNS (USA ONLY)

To obtain warranty service, a Return Materials Authorization (RMA) number must first be obtained from ELATION. It is the Customer's responsibility to provide product proof of purchase and serial number by acceptable evidence such as an invoice copy or an approved ELATION Extended Warranty Certificate ("EWC") and any relevant maintenance records at the time warranty service is sought. Failure to provide acceptable evidence of product proof of purchase or EWC and any relevant maintenance records may be cause for denial of warranty service.

Products returned for warranty service must be sent without any accessories (i.e., power, data, and safety cables, brackets, clamps, rigging hardware, frost filters, gel frames, barn doors, lens, hoses, nozzles, rack mounting hardware, etc.), must be boxed using the original and/or suitable packaging materials (double-box and foam) that provides ample product protection for ground and/or air freight transit, and must be shipped freight pre-paid and insured to ELATION in Los Angeles, CA or an ELATION Authorized Service Center. The RMA number must be clearly written on the outside of the return box, and a brief description of the problem and the RMA number must be documented and included in the box.

Products returned for warranty service without an RMA number clearly marked on the outside of the package will be refused and returned to the shipper at the Customer's expense. Products returned for warranty service, which are received damaged due to inadequate and/or improper packaging and/or due to damage caused by shipping carrier, may incur additional repair charges before warranty service begins and/or may void this warranty. If any product accessories (included and/or optional) are shipped with the product, ELATION and/or the ELATION Authorized Service Center shall have no liability what so ever for the loss and/or damage to any such accessories, nor the safe return thereof. If the requested warranty repairs or service (including parts replacement) are within the terms of this warranty, ELATION will pay return ground transportation shipping charges to a single designated point within the United States.

SAFETY GUIDELINES

This fixture is an extremely sophisticated piece of electronic equipment. To guarantee a smooth operation, it is important to follow all instructions and guidelines in this manual. The manufacturer of this device is not responsible for injury and/or damages resulting from the misuse of this fixture due to the disregard of the information printed in this manual. Only qualified and/or certified personnel should perform installation of this fixture and only the original rigging parts (omega brackets) included with this fixture should be used for installation. Any modifications to the fixture and/or the mounting hardware included will void the original manufactures warranty and increase the risk of damage and/or personal injury.



PROTECTION CLASS 1 - FIXTURE MUST BE PROPERLY GROUNDED



DO NOT PLUG FIXTURE INTO A DIMMER PACK!

NEVER OPEN THIS FIXTURE WHILE IN USE!

UNPLUG POWER BEFORE SERVICING FIXTURE!

NEVER TOUCH FIXTURE DURING OPERATION, AS IT MAY BE HOT!

KEEP FLAMMABLE MATERIALS AWAY FROM FIXTURE!



INDOOR / DRY LOCATIONS USE ONLY!

DO NOT EXPOSE FIXTURE TO RAIN AND MOISTURE!



NEVER LOOK DIRECTLY INTO THE LIGHT SOURCE!

RETINA INJURY RISK - MAY INDUCE BLINDNESS!

SENSITIVE PERSONS MAY SUFFER AN EPILEPTIC SHOCK!

DO NOT TOUCH the fixture housing during operation. Turn OFF the power and allow approximately 15 minutes for the fixture to cool down before serving.

DO NOT shake fixture, avoid brute force when installing and/or operating fixture.

DO NOT operate fixture if the power cord has become frayed, crimped, damaged and/or if any of the power cord connectors are damaged and do not insert into the fixture securely with ease. **NEVER** force a power cord connector into the fixture. If the power cord or any of its connectors are damaged, replace it immediately with a new one of similar power rating.

DO NOT block air ventilation slots. All air/fan inlets must remain clean and never blocked.

Allow approx. 6" (15cm) between fixture and other devices or a wall for proper cooling.

When installing fixture in a suspended environment, always use mounting hardware that is no less than M10 x 25 mm, and always install fixture with an appropriately rated safety cable.

Always disconnect fixture from main power source before performing any type of service and/or cleaning procedure. Only handle the power cord by the plug end, never pull out the plug by tugging the wire portion of the cord.

During the initial operation of this fixture, a light smoke or smell may emit from the interior of the fixture. This is a normal process and is caused by excess paint in the interior of the casing burning off from the heat associated with the lamp and will decrease gradually over time.

Consistent operational breaks will ensure fixture will function properly for many years.

MAINTENANCE GUIDELINES



DISCONNECT POWER BEFORE PERFORMING ANY MAINTENANCE!

CLEANING

Frequent cleaning is recommended to insure proper function, optimized light output, and an extended life. The frequency of cleaning depends on the environment in which the fixture operates: damp, smoky or particularly dirty environments can cause greater accumulation of dirt on the fixture's optics. Clean the external lens surface at least every 20 days with a soft cloth to avoid dirt/debris accumulation.

NEVER use alcohol, solvents, or ammonia-based cleaners.

MAINTENANCE

Regular inspections are recommended to insure proper function and extended life.

There are no user serviceable parts inside this fixture, please refer all other service issues to an authorized Elation service technician. Should you need any spare parts, please order genuine parts from your local Elation dealer.

Please refer to the following points during routine inspections:

A detailed electric check by an approved electrical engineer every three months, to make sure the circuit contacts are in good condition and prevent overheating.

Be sure all screws and fasteners are securely tightened at all times. Loose screws may fall out during normal operation resulting in damage or injury as larger parts could fall.

Check for any deformations on the housing, color lenses, rigging hardware and rigging points (ceiling, suspension, trussing). Deformations in the housing could allow for dust to enter into the fixture. Damaged rigging points or unsecured rigging could cause the fixture to fall and seriously injure a person(s).

Electric power supply cables must not show any damage, material fatigue or sediments.

NEVER remove the ground prong from the power cable.

FIXTURE OVERVIEW

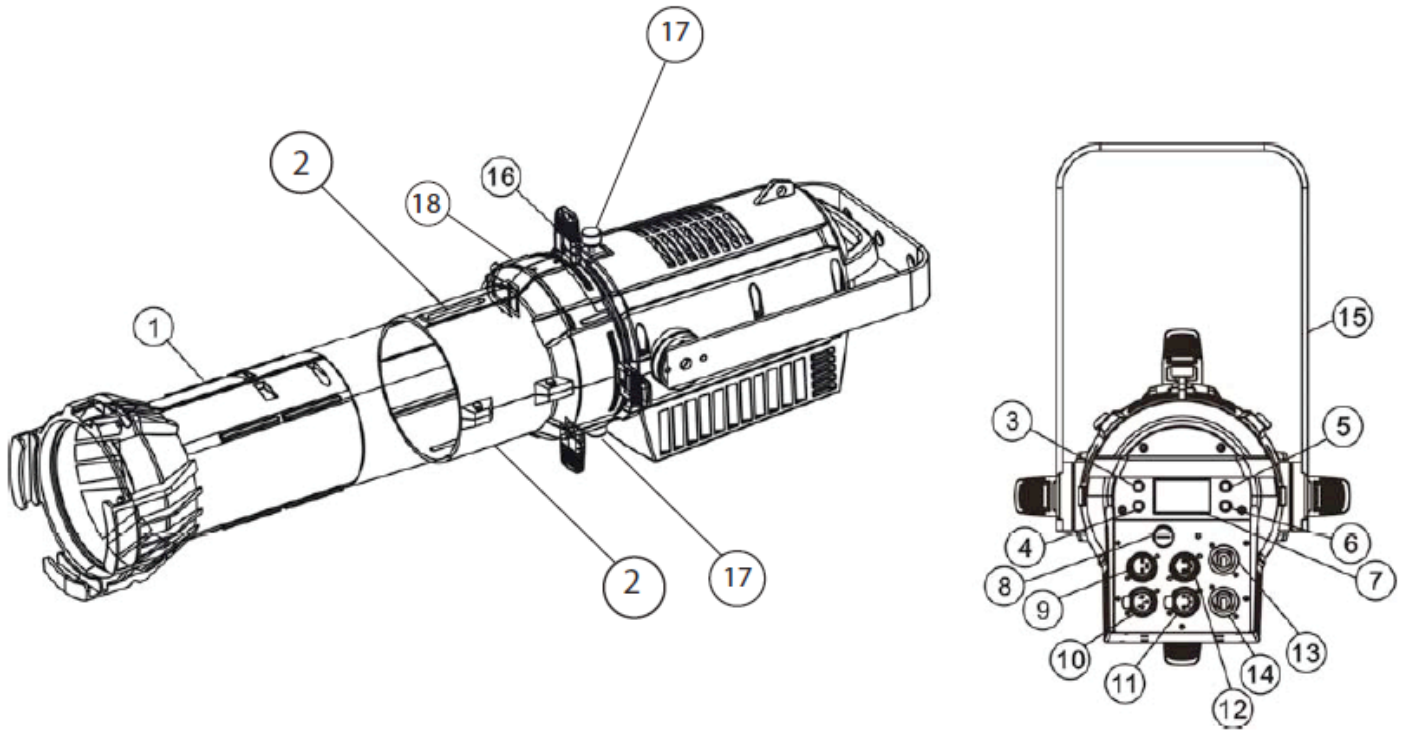

- | | |
|-----------------------------|--------------------|
| 1. Lens (not included) | 10. 3pin DMX IN |
| 2. FOCUS | 11. 3pin DMX OUT |
| 3. UP Button | 12. 5pin DMX OUT |
| 4. DOWN Button | 13. Power IN |
| 5. MODE/ESC Button | 14. Power OUT |
| 6. ENTER Button | 15. Mounting Yoke |
| 7. LCD Menu Control Display | 16. BLADE SHUTTERS |
| 8. FUSE | 17. ROTATION |
| 9. 5pin DMX IN | 18. Gobo Slot* |

*Gobo and Holder not included

LENS AND GOBO HOLDER INSTALLATION

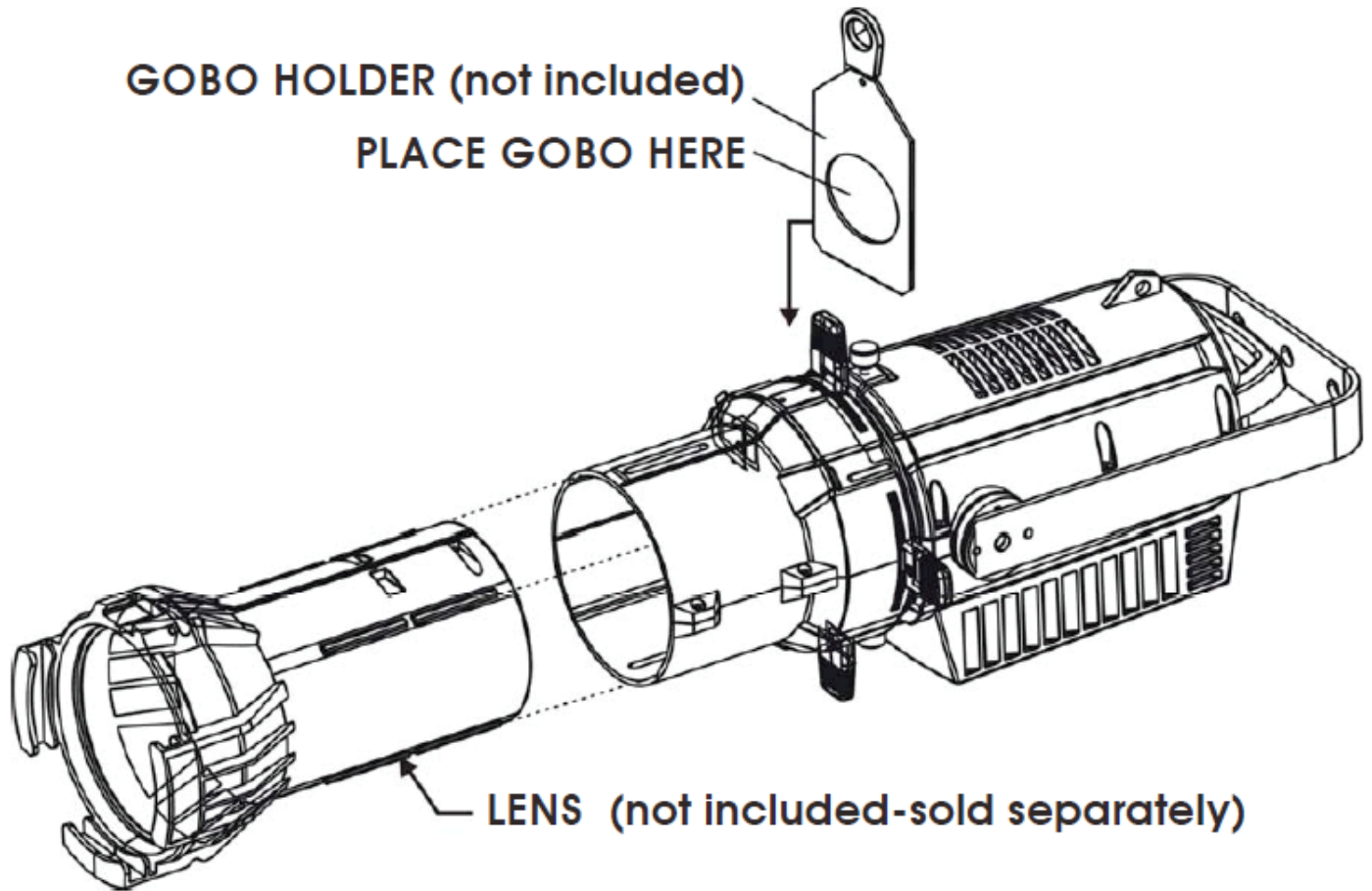

Options Available in 19° / 26° / 36° / 50° Fixed Beams



* Gobo Holder (not included)

Supports "B" Size Metal and HT Transparency Gobos (not included)

FIXTURE INSTALLATION



WARNING

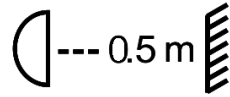

Minimum distance to lighted objects 0.5 meters.

Minimum distance of inflammable materials from the surface 0.5m.



FLAMMABLE MATERIAL WARNING

Keep fixture minimum 5.0 feet (1.5m) away from flammable materials and/or pyrotechnics.



ELECTRICAL CONNECTIONS

A qualified electrician should be used for all electrical connections and/or installations.



USE CAUTION WHEN POWER LINKING OTHER MODEL FIXTURES AS THE POWER CONSUMPTION OF OTHER MODEL FIXTURES MAY EXCEED THE MAX POWER OUTPUT ON THIS FIXTURE. CHECK SILK SCREEN FOR MAX AMPS.



DO NOT INSTALL THE FIXTURE IF YOU ARE NOT QUALIFIED TO DO SO!

Fixture **MUST** be installed following all local, national, and country commercial electrical and construction codes and regulations.

Before rigging/mounting a single fixture or multiple interconnected fixtures for custom matrix designs to any metal truss/structure or placing the fixture(s) on any surface, a professional equipment installer **MUST** be consulted to determine if the metal truss/structure or surface is properly certified to safely hold the combined weight of the fixture(s), clamps, cables, and accessories.

Fixture ambient operating temperature range is **14° to 113°F. (-10° to 45°C)**

Do not use the fixture under or above this temperature.

Fixture(s) should be installed in areas outside walking paths, seating areas, or away from areas where unauthorized personnel might reach the fixture by hand.

NEVER stand directly below the fixture(s) when rigging, removing or servicing.

Overhead fixture installation must always be secured with a secondary safety attachment, such as an appropriately rated safety cable that meets all local, national, and country codes and regulations. Allow approximately 15 minutes for the fixture to cool down before serving.

FIXTURE INSTALLATION

CLAMP MOUNTING

This fixture includes an adjustable mounting yoke and safety cable rigging point attached to the fixture (see the illustration below). When mounting this fixture to truss, be sure to secure an appropriately rated clamp (not included) to the yoke using an M10 screw and attach a **SAFETY CABLE** to the fixture safety cable rigging point.

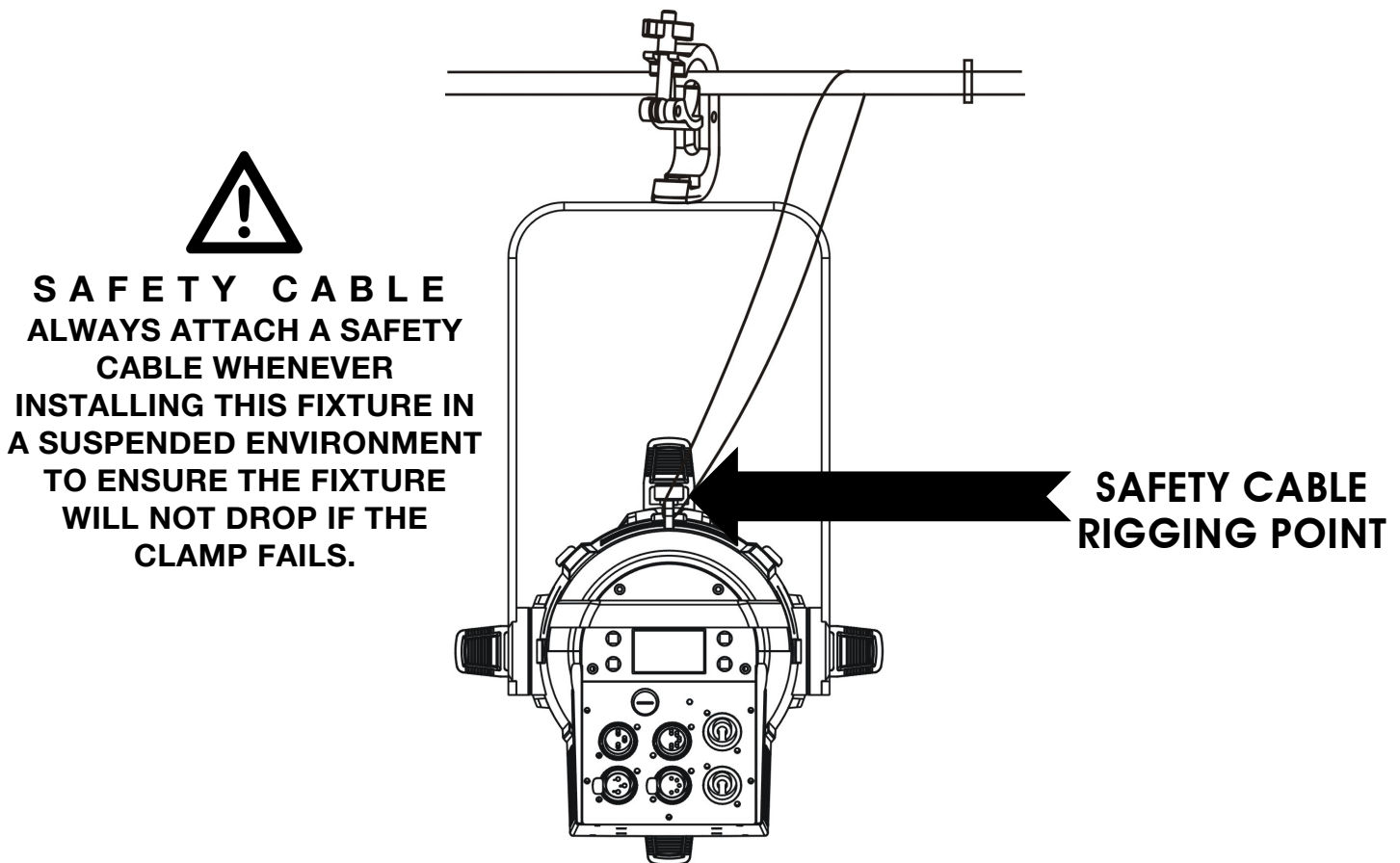

RIGGING

Overhead rigging requires extensive experience, including amongst others calculating working load limits, installation material being used, and periodic safety inspection of all installation material and the fixture. If you lack these qualifications, do not attempt the installation yourself. Improper installation can result in bodily injury.

SYSTEM MENU

The fixture includes an easy to navigate system menu. The control panel (see image below) located on the front of the fixture, provides access to the main system menu and is where all necessary system adjustments are made to the fixture. During normal operation, pressing **MODE/ESC** button once will access the fixture's main menu. Once in the main menu you can navigate through the different functions and access the sub-menus with the **UP**, **DOWN**, **RIGHT**, and **LEFT** buttons. Once you reach a field that requires adjusting, press the **ENTER** button to activate that field and use the **UP** and **DOWN** buttons to adjust the field. Pressing the **ENTER** button once more will confirm your setting. You may exit the main menu at any time without making any adjustments by pressing the **MODE/ESC** button.

To access the LCD Menu Control Display via the internal battery, press and hold the **MODE/ESC** button for 3 seconds. The LCD Menu Control Display will shut **OFF** automatically about 1 minute from the last button press.

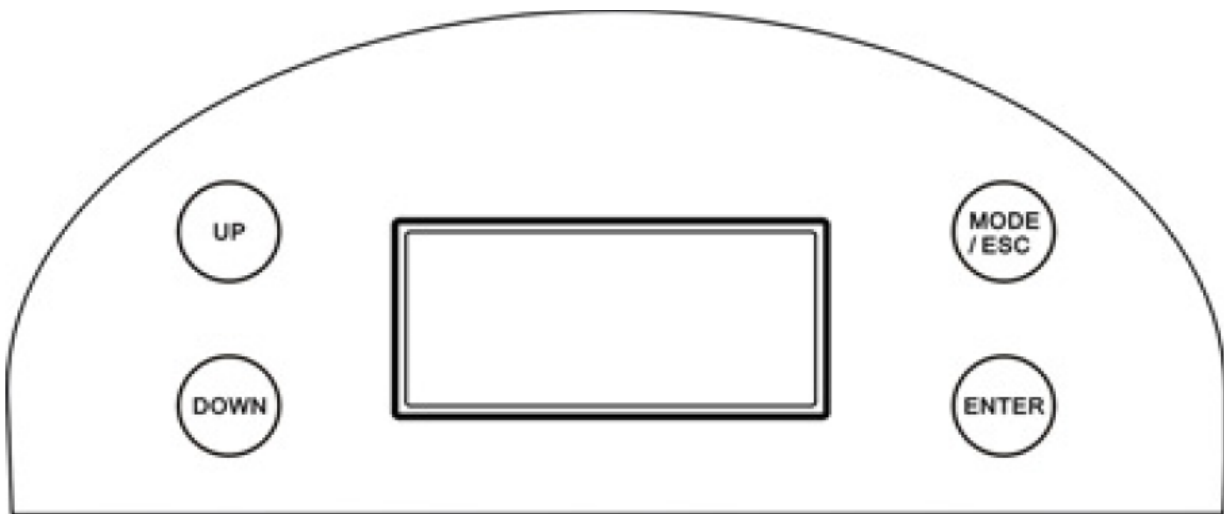

**ELATION CW PROFILE HP
SYSTEM MENU**

Supports Software Versions: ≥1.1.1A

Features are subject to change without any prior written notice.

MAIN MENU	SUB MENU	OPTIONS / VALUES (Default Settings in BOLD)	DESCRIPTION
FuncMode	Address	001 ~512	DMX Address Setting
	ValuDisp	=All Ch, White, Dimm_F, Stro, Dimm_Mo	DMX Value Display
	SetSecondry	Secondry1, Secondry2, Secondry3	Secondary Setting
	AutoProg	Alone / Primary	Auto Program
Info	TimeInfo	Cur Time	XXXX(Hours) Power On Running Time
		TotalHrs	XXXX(Hours) Fixture Running Time
		Last Hrs	XXXX(Hours) Fixture Last Times Clear
		TimePass	Password=XXX Timer Password 038
		Clr Last	ON/OFF Clear Fixture Last Time ***Timer Password Required***
	TempInfo	HeadTemp	XXX C° / F ° Temperature in Fixture
Soft Ver	=1.1.1A (or greater)		Software Version
Persnal	Stat Set	Addr DMX	ON/OFF Address Via DMX
		NoDMXSta	CloShut/ Hold /Auto Auto Run If No DMX
		Off Time	02~60m 05m LCD Display Shut Off Time
	Disp Set	Key Lock	ON/OFF When ON, Control Panel Buttons Lock After 15 secs. Press/Hold MODE/ESC Button For 3 secs to Unlock.
		Temp C/F	Cels/Fahren Temperature Switch Between C°/ F°
	Man Hold	ON/OFF Keep Manual Settings after Power Loss	
	Refresh	Fq = 900 - 1500, 25000 (1200) Refresh Frequency Rate Setting	
	Gamma	Gama = 2.0, 2.2 , 2.4, 2.8 Gamma Setting	
ResetDef	ON/OFF Passcode 011 Restore factory settings		
ManCntrl	ManCntrl	Cool= 000 -255 DimF= 000 -255 Stro= 000 -255 DIMo= 000 -255 Adjust Functions Manually	
	Calibrat	Password	Passcode 050 Calibration Password 050
		White [255-0]	Calibrate LED
Mode Set	UserMode	=1CH , =4CH DMX Channel Modes	
Dimming	DimModes	Standar , Stage, TV, Archite, Theatre Dimming Curve Modes	
EditProg	Sel Prog	ProPart1 = Prog 1~10 (Program 1)	
		ProPart2 = Prog 1~10 (Program 2)	
		ProPart3 = Prog 1~10 (Program 3)	
	EditProg	Prog 1	ProgTest = T01SCxxx Testing Program
		:	EdStep 01 = S01SCxxx Program In Loop
Prog 10		EdStep 64 = S64SCxxx Save and Exit	
EditScen	Scene 001 ~ Scene 250	Cool = Cool=xxx ~ InByOut = Time=xx.xs Save and Automatically Return Manual Scenes Edit	
RecCntrl	XX~XX	Automatic Scenes Recorder	

SYSTEM MENU CHANGE WITH SOFTWARE UPDATE VERSION ≥1.1.2

See highlighted menu items below which have been updated with this software update.

SYSTEM MENU - Supports Software Versions: ≥1.1.2				
Features are subject to change without any prior written notice.				
MAIN MENU	SUB MENU	OPTIONS / VALUES (Default Settings in BOLD)		DESCRIPTION
Persnal	Stat Set	Addr DMX	ON/OFF	Address Via DMX
		NoDMXSta	CloShut/ Hold /Auto	Auto Run If No DMX
	Serv Set	Password	Password=XXX	RDM UID Password 050
		RDM UID		RDM UID
Refresh	Fq=900-(1200)-1500, 2.5K, 4K, 5K, 6K , 10K, 15K, 20K, 25K		Refresh Frequency Rate Setting	
ManCntrl	ManCntrl	Whit =000-255 DimF=000-255 Stro=000-255 DIMo=000-255		Adjust Functions Manually

Persnal - Stat Set - Addr DMX

When ON, define the desired fixture DMX address via an external controller.

NOTE: This process assumes the fixture DMX address is set to 001. If fixture DMX address is not at 001, you must adjust the channel numbers listed below accordingly in order for this feature to work.

For example: if your fixture address is 010, then Channel 1 becomes Channel 10, Channel 2 becomes Channel 11, and Channel 3 becomes Channel 12.

1. Connect the fixture to the external controller and power ON.
2. Set the DMX value of **Channel 1** on the controller to **(7)**.
3. Set the DMX value of **Channel 2** on the controller to **(7)** or **(8)**.
When set to **(7)**, the DMX address can be set between **(1)** and **(255)**.
When set to **(8)**, the DMX address can be set between **(256)** and **(511)**.
4. Using **Channel 3** on the controller set the desired DMX address of the fixture.

Example 1: If the desired DMX address is **57**, set **Channel 1** to a value of **(7)**, set **Channel 2** to a value of **(7)**, and then set **Channel 3** to a value of **(57)**.

Example 2: If the desired DMX address is **420**, set **Channel 1** to a value of **(7)**, set **Channel 2** to a value of **(8)**, and then set **Channel 3** to a value of **(164)**. (256+164=420)

5. After setting **Channel 3** to the desired DMX address value, wait approximately 20-45 seconds for the new address to be assigned to the fixture.

Dimming – DimModes

Select dimming modes (Standar, Stage, TV, Archite, Theatre).

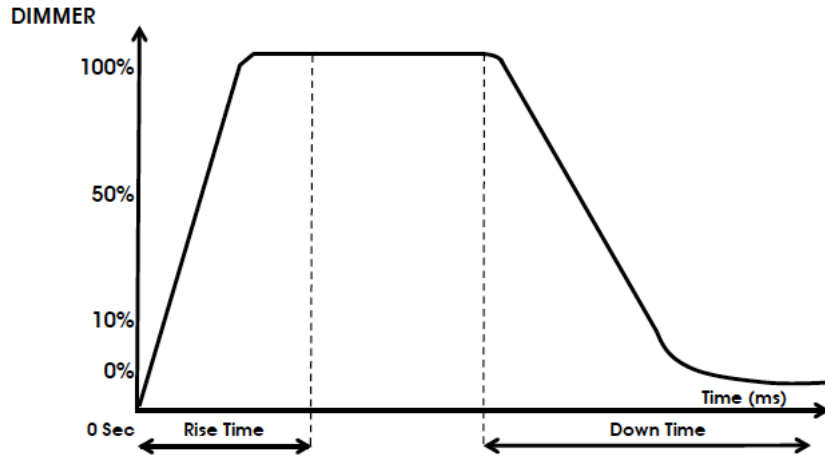

Dimming Curve Ramp Effect	0 sec Fade Time		1 sec Fade Time	
	Rise Time (ms)	Down Time (ms)	Rise Time (ms)	Down Time (ms)
Standard (default)	0	0	0	0
Stage	780	1100	1540	1660
TV	1180	1520	1860	1940
Architectural	1380	1730	2040	2120
Theatre	1580	1940	2230	2280

Personal - Reset Default (011)



ONLY QUALIFIED TECHNICIANS SHOULD PERFORM THIS FUNCTION.

NOTE: SAVED WHITE BALANCE IS ERASED AFTER A RESET IS PERFORMED.

This function restores all fixture settings to the factory default settings. The password is **011** and must be entered each time a reset is performed.

EditProg – Sel Prog

Select one of the (10) user defined internal Auto Programs.

EditProg – EditProg

Edit any of the (10) user defined internal Auto Programs.

EditProg – EditScen

Edit any of the (250) scenes of the internal Auto Programs.

EditProg – RecCntrl

The fixture features an integrated DMX-recorder by which you can transmit the programmed scenes from your DMX-controller to the moving head. Adjust the desired scene numbers via the encoder (from – to). When you call up the scenes at your controller, they will automatically be transmitted to the moving head.

EDIT PROGRAM – Record Controller – Working With Built In Programs

A Primary unit can send up to 3 different data groups to the Secondary units, i.e. a Primary unit can start 3 different Secondary units, which run 3 different programs. The Primary unit sends the 3 program parts in a continuous loop.

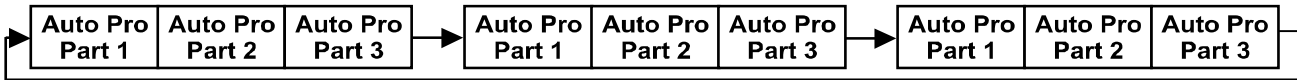

The Secondary unit receives data from the Primary unit according to the group which the Secondary unit was assigned to. If e.g. a Secondary unit is set to “**Secondary 1**” in the menu “**Set to Secondary**”, the Primary unit sends “**Auto Program Part 1**” to the Secondary unit. If set to “**Secondary 2**”, the Secondary unit receives “**Auto Program Part 2**”.

To start an Auto Program proceed as follows:

1. Secondary Setting

- Select “**Function Mode**”.
- Press **ENTER** to confirm.
- Select “**Set to Secondary**”.
- Press **ENTER** to confirm.
- Select “**Secondary 1**”, “**Secondary 2**” or “**Secondary 3**”.
- Press **ENTER** to confirm.
- Press **MODE/ESC** in order to return to the main menu.

2. Automatic Program Run

- Select “**Function Mode**”.
- Press **ENTER** to confirm.
- Select “**Auto Program**”.
- Press **ENTER** to confirm.
- Select “**Primary**” or “**Alone**”.
- Press **ENTER** to confirm.
- Press **MODE/ESC** in order to return to the main menu.

EDIT PROGRAM – Record Controller – Working With Built-In Program [continued]

3. Program Selection for Auto Pro Part

- Select **“Edit Program”**.
- Press **ENTER** to confirm.
- Select **“Select Programs”**.
- Press **ENTER** to confirm.
- Select **“Auto Pro Part 1”**, **“Auto Pro Part 2”** or **“Auto Pro Part 3”**, and select which Secondary program is to be sent. Selection **“Part 1”** means, that the Secondary unit runs the same program as the Primary units.
- Press **ENTER** to confirm.
- Press **MODE/ESC** in order to return to the main menu.

4. Program Selection for Edit Program

- Select **“Edit Program”**.
- Press **ENTER** to confirm.
- Select **“Edit Program”**.
- Press **ENTER** to confirm.
- Select the desired program to edit specific scenes into a specific program.
- Press **ENTER** to confirm.
- Press **MODE/ESC** in order to return to the main menu.

5. Automatic Scene Recording

- Select **“Edit Program”**.
- Press **ENTER** to confirm.
- Select **“Edit Scenes”**.
- Select desired scene numbers. A maximum of 250 scenes can be programmed.
- Press **ENTER** to confirm.
- Press **MODE/ESC** in order to return to the main menu.

EDIT PROGRAM – Record Controller – Working With Built-In Program [continued]

Example:

Program 2 includes scenes: 10, 11, 12, & 13

Program 4 includes scenes: 8, 9, & 10

Program 6 includes scenes: 12, 13, 14, & 15

Auto Pro Part 1 is Program 2

Auto Pro Part 2 is Program 3

Auto Pro Part 3 is Program 6

The 3 Secondary groups run the Auto Program in certain time segments. (See diagram below)

Part 1:

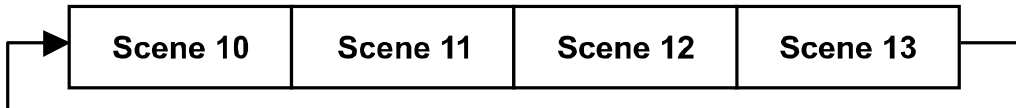

Part 2:

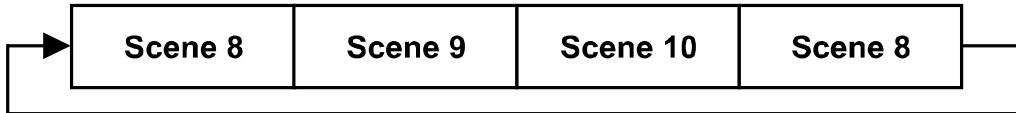

Part 3:

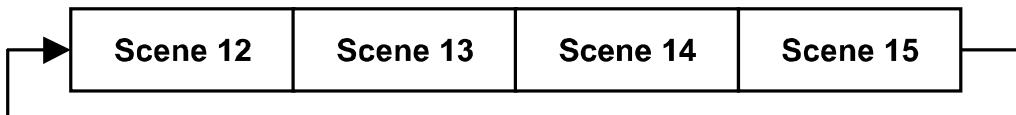

DMX CHANNEL FUNCTIONS AND VALUES

RELATION CW PROFILE HP			
DMX Channel Values / Functions (4 DMX Channels)			
Specifications are subject to change without any prior written notice.			
MODE / CHANNEL		VALUE	FUNCTION
1CH	4CH		
1	1		DIMMER
		0-255	Intensity 0 to 100%
	2		DIMMER FINE
		0-255	FINE Intensity 0 to 100%
	3		STROBE
		0-31	LED OFF
		32-63	LED ON
		64-95	Strobe Effect SLOW to FAST
		96-127	LED ON
		128-159	Pulse Effect In Sequences
		160-191	LED ON
		192-223	Random Strobe Effect SLOW to FAST
	224-255	LED ON	
	4		DIMMING CURVES
		0-20	STANDARD
		21-40	STAGE
		41-60	TV
		61-80	ARCHITECTURAL
		81-100	THEATRE
		101-255	Default to Unit Dimming Curve Setting

S P E C I F I C A T I O N S

SOURCE

High Power 130W Cool White LED

50,000 Hour Average LED Life*

*Lab test conditions. May vary depending on several factors including but not limited to:
Environmental Conditions, Power/Voltage, Usage Patterns (On-Off Cycling), Control, and Dimming.

EFFECTS

Electronic Strobe and 16bit Dimming

Selectable Dimming Curve Modes

GOBOS

Supports “B” Size Metal and HT Transparency Gobos (static gobo holder not included)

CONTROL / CONNECTIONS

2 DMX Channel Modes (1/ 4)

Adjustable Refresh Rate

Adjustable Gamma Brightness

4 Button Control Panel / LED Menu Display

3/5pin DMX In/Out / power In/Out

SIZE / WEIGHT

Length: 24.3” (618mm)

Width: 12.2” (310mm)

Vertical Height: 15.7” (398mm)

Weight: 21.0 lbs. (9.5 kg)

ELECTRICAL / THERMAL

AC 100-240V - 50/60Hz

160W Max Power Consumption

14°F to 113°F (-10°C to 45°C)

APPROVALS / RATINGS



Specifications and improvements in the design of this unit and this manual are subject to change without any prior written notice.

FCC STATEMENT

This device complies with Part 15 of the FCC Rules. Operation is subject to the following two conditions: (1) this device may not cause harmful interference, and (2) this device must accept any interference received, including interference that may cause undesired operation.

FCC RADIO FREQUENCY INTERFERENCE WARNINGS & INSTRUCTIONS

This product has been tested and found to comply with the limits as per Part 15 of the FCC Rules. These limits are designed to provide reasonable protection against harmful interference in a residential installation. This device uses and can radiate radio frequency energy and, if not installed and used in accordance with the included instructions, may cause harmful interference to radio communications. However, there is no guarantee that interference will not occur in a particular installation. If this device does cause harmful interference to radio or television reception, which can be determined by turning the device off and on, the user is encouraged to try to correct the interference by one or more of the following methods:

- Reorient or relocate the device.
- Increase the separation between the device and the receiver.
- Connect the device to an electrical outlet on a circuit different from which the radio receiver is connected.
- Consult the dealer or an experienced radio/TV technician for help.

DIMENSIONAL DRAWINGS

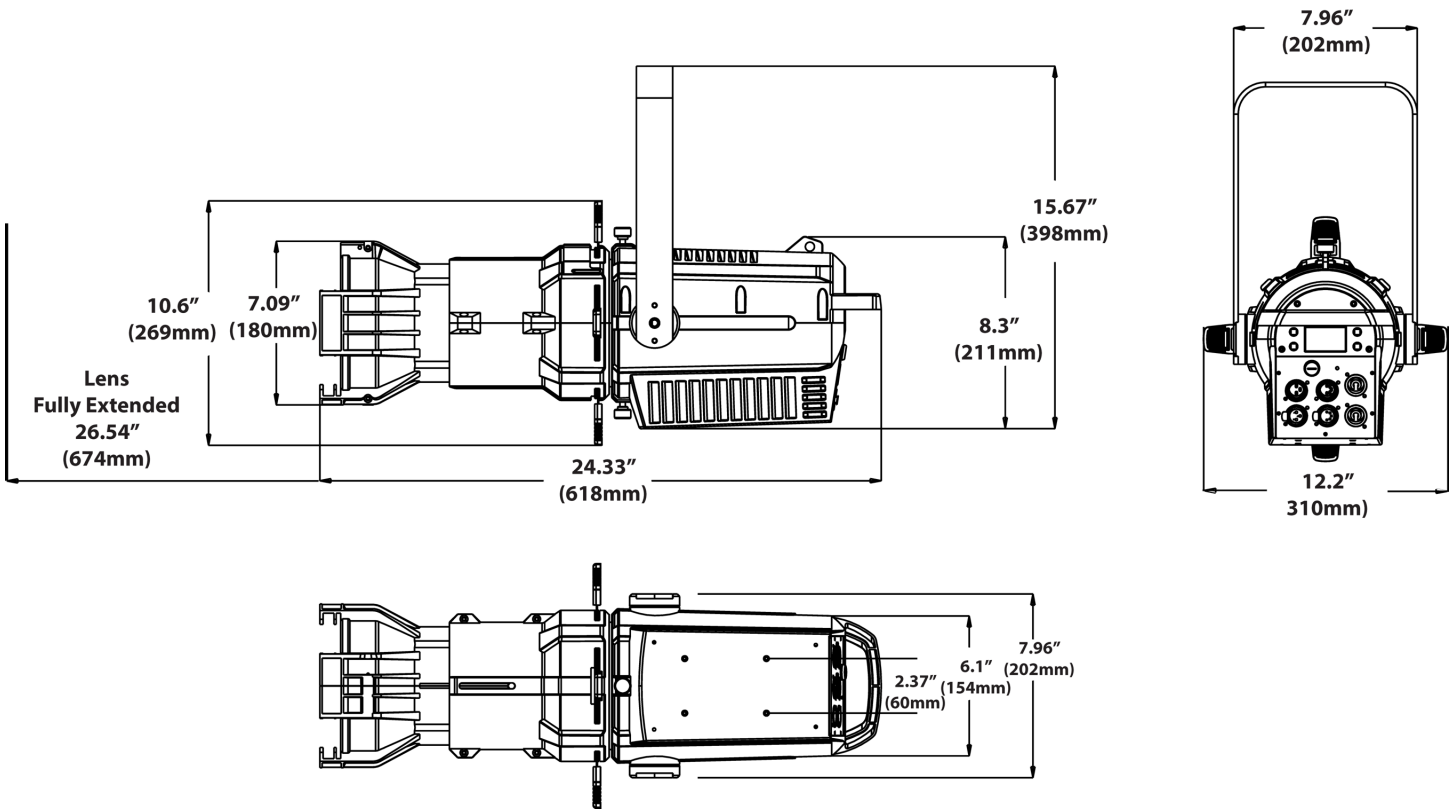

*DRAWINGS NOT TO SCALE

Specifications and improvements in the design of this unit and this manual are subject to change without any prior written notice.

OPTIONAL ACCESSORIES

ORDER CODE	ITEM
QUICK RIG CLAMP	Low Profile Quick Release Clamp
PHD019	Profile High Definition Lens 19°
PHD126	Profile High Definition Lens 26°
PHD236	Profile High Definition Lens 36°
PHD350	Profile High Definition Lens 50°
AC3PDMX5PRO	5 ft. (1.5m) 3pin PRO DMX Cable
AC5PDMX5PRO	5 ft. (1.5m) 5pin PRO DMX Cable
NEU088	3 ft. (1m) Power Link Cable
	Additional Cable Lengths Available

