



Artistic Licence



Rail-Switch II

User Guide



Please read these instructions before using the product.

This product has been designed & manufactured for professional use only. It should only be installed by a suitably qualified technician and in accordance with electrical regulations in the country of use.

Unless directed in the instructions there are no user serviceable parts inside the outer case of this product.

Always disconnect from the power supply when not in use.

Any specific IP rating, where appropriate, is given in the instructions. Unless otherwise stated this product is designed for indoor use only. If used outdoors it **MUST** be installed in an appropriate IP rated cabinet. Do not allow this product to be exposed to rain or moisture. Do not allow liquid to penetrate the product.

Please recycle all packaging.

Copyright © Artistic Licence Engineering Ltd. All rights reserved.

Download the user guide by scanning the following QR code:



Connections

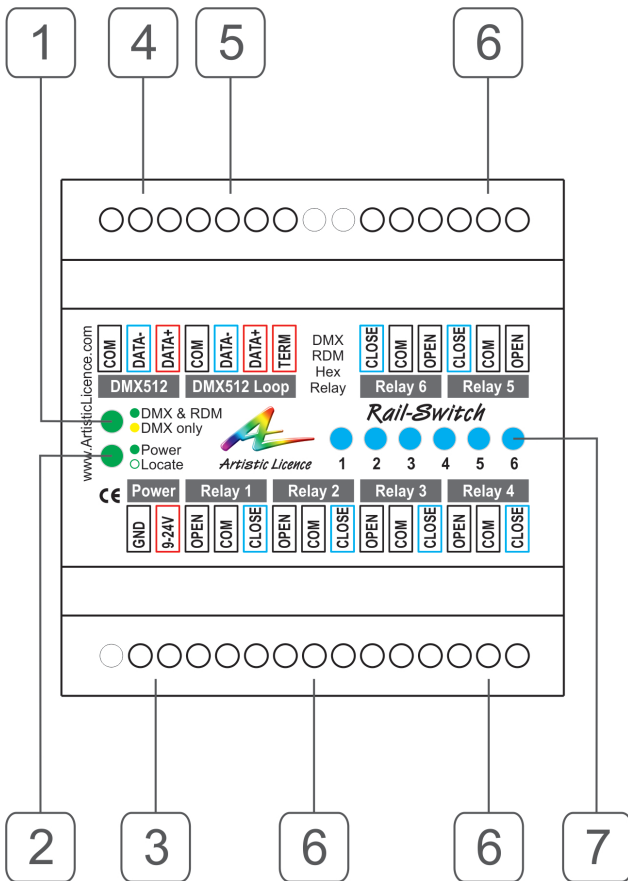

Reference	Type	Description
1	LED	Data type
2	LED	Power/ RDM locate
3	Connection	Power Input
4	Connection	DMX512 Input
5	Connection	DMX512 Loop & Term
6	Connection	Relay Outputs
7	LED	Relay energised

** A passive loop-through connection allows onward connection to other DMX512 devices. If this feature is not required then the signal must be terminated. The product contains an internal termination resistor. This is enabled by fitting a wire link between **Term** and **DAT+**.

DMX512 Wiring

XLR Pin (Convention)	Function	Colour
1	Ground	Black
2	Data -	Blue
3	Data +	Red

Internal Earth and Isolation

Circuit	Description	
DMX512 Input (including Loop Through)	Type:	Non-isolated
	Pin 1:	Connects to Internal Logic Ground
Relay Outputs	Isolated, volt-free	
Internal Logic Ground	Connects to Ground Power Input	

Mounting Diagram

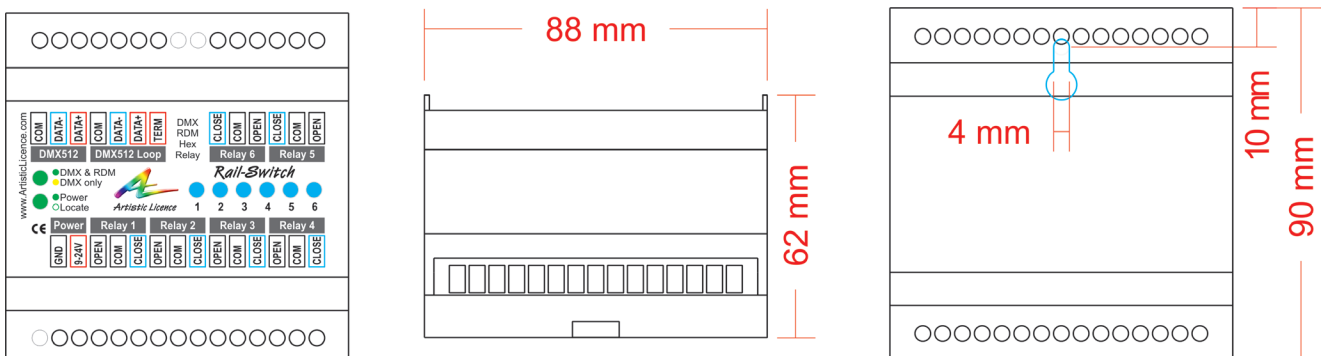

Overview

In theatre, touring and architectural applications there are invariably some devices that do not provide a useful form of remote control. Rail-Switch II is an elegant solution to the automation of these devices.

Rail-Switch II is a DIN Rail mounted device that provides 6 mains voltage relays and is controlled via DMX512 & RDM. Each relay can be switched independently. The product is powered via an external DC power supply unit.

The product is configurable using RDM. This is particularly useful in enabling the start address of each relay to be set individually.

Summary of Key Features

- 6 mains relays
- Relays rated at 250V AC, 8A non-inductive
- DMX/RDM controlled
- LED indication for data, power and each relay output
- Simulated RDM sub-devices for start address programming
- Preset mode eliminates need for DMX controller
- Data loss and test modes
- DIN Rail or surface mount

Connections

Input

The DMX512 input is attached via a 3-pin screw terminal. Please refer to the connections diagram.

Loop Through

A passive loop-through connection allows onward connection to other DMX512 devices. If this feature is not required then the signal must be terminated. The product contains an internal termination resistor. This is enabled by fitting a wire link between the screw terminals that will terminate the DMX line (Term and DAT+).

Output

Six relay outputs are provided. It is recommended that the output wires are fitted with separate ferrite cores when driving a high current load.

Power

Rail-Switch II is be powered from an external DC power supply (9-24 VDC). It is recommended that a ferrite core be fitted onto the DC power lines as close as possible to the Rail-Switch II. This protects the unit from any electrical spikes that appear on the DC line.

Relays

The relays energise at a DMX value of 128. Each relay has three connections; Common, Normally Open and Normally Closed.

Common (C)

This connection is always used and is connected to either the open or closed pin depending on the state of the relay.

Normally Open (NO)

This pin is not normally connected to the Common pin. The relay must be energised for a connection to be made.

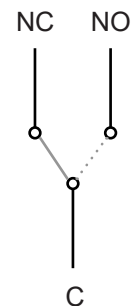

Normally Closed (NC)

This pin is connected to Common when the relay is not energised.

Loading

Rail-Switch II uses electromechanical relays that are rated for 8A at 250 VAC when switching non-inductive loads. The product can be used to drive inductive loads, or those with high inrush currents, so long as external surge protection is added. These devices stop the contacts from being damaged by arcing. Part code 'Sequence-Filter' is an external PTC filter suitable for this purpose.

The user must also ensure that external circuit protection such as circuit breakers or fuses are connected in compliance with the local wiring regulations.

LED Indication

Rail-Switch II has front-panel LED indicators for the following functions:

Data (upper):

OFF = no data received

Green = DMX and RDM received

Yellow = DMX only received

Alternating green/yellow = Rail-Switch II is in preset playback mode or test mode (see 'Configuration' below)

Power/Locate (lower):

Green = Power

Flashing green = RDM locate is active

An RDM locate sent to the root or the sub-devices will have the identical effect of causing the power indicator to flash.

Relays 1 - 6 (right-hand side):

Blue = Relay is energised

Configuration

Rail-Switch II uses one channel to control each relay, requiring 6 channels in total.

There are various configuration options (including start address programming). These are accessed using RDM, which requires a suitable programming interface.

One option is Commissioner rdmx, a handheld RDM programming tool available from Artistic Licence.

Alternatively, Rail-Switch II can be connected to an Art-Net network using an interface product such as Art-Lynx O/P or Net-Lynx O/P. Configuration is then achieved using DMX-Workshop, a PC software application for managing Art-Net networks (available as a free-of-charge download from the Artistic Licence website, www.artisticlicence.com).

DMX-Workshop

This windows-based application provides a convenient means of accessing the Rail-Switch II configuration menus. DMX-Workshop can also be used for product firmware uploads.

Start address programming

In the DMX-Workshop 'Node List' screen, Rail-Switch II appears as an RDM device, with each relay listed as a sub-device (see screenshot below).

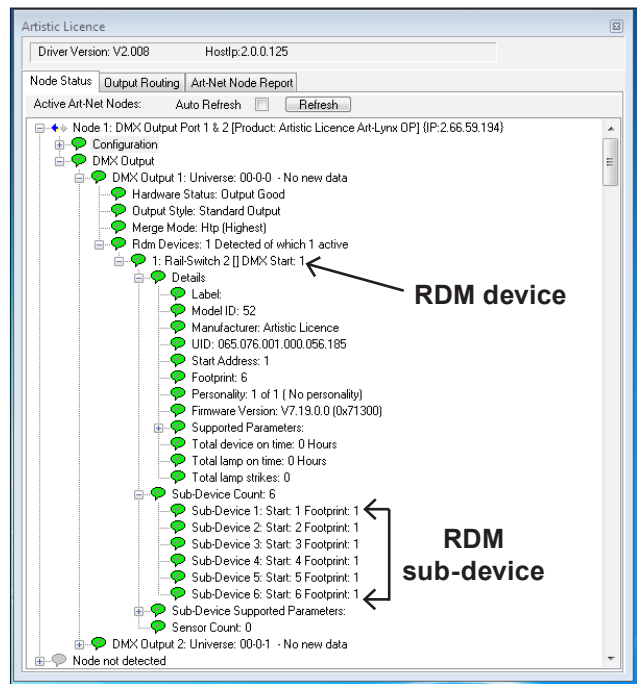

If the user wishes all 6 output channels to be consecutively addressed, this is achieved by setting the RDM device start address (right-click on the RDM device entry). Alternatively, if the user wishes to individually set the address of each channel, this is achieved by setting the start address of each sub-device (right-click on the desired RDM sub-device).

Generally, right-clicking on any entry brings up a menu of the available options.

Preset mode

It is possible to pre-programme Rail-Switch II such that it can be installed without a DMX controller. Rail-Switch II has 8 preset memories which can be used to record different on/off combinations of the six relay outputs.

DMX-Workshop allows these settings to be captured and played back. To access the relevant menus, right-click on the Rail-Switch II RDM device (as shown above). Please note that the data captured is always the DMX512 input, independent of the currently selected output.

Preset playback is non-volatile. This means that if a preset is played back, Rail-Switch II can be then disconnected from DMX and power cycled and will still playback the preset.

Data loss mode

DMX-Workshop (or a suitable RDM tool) also allows programming of data loss mode. This mode is intended to be used when Rail-Switch II is being controlled by DMX (i.e. when it is not running in preset mode).

The data loss programming determines what Rail-Switch II should do if DMX is lost for more than 2.5 seconds. It can be selected to play one of the 8 presets or hold the last state. If DMX returns, the control is immediately returned. Rail-Switch II will also power up in this mode until DMX is detected.

To access the data loss mode menu, right-click the Rail-Switch II RDM device, then go to Advanced - Artistic Licence products - Data loss mode.

Test mode

Rail-Switch II offer two test patterns:

Test 1 = all outputs on

Test 2 = all outputs off

DMX-Workshop (or suitable RDM tool) can be used to put the product in test mode, which can be useful during show commissioning or rehearsals.

To access the data test mode selections, right-click the Rail-Switch II RDM device, then go to 'Self test'.

Output priority

The priority of output is as follows (highest at the top):

1. Test pattern
2. Preset playback
3. Data loss event
4. DMX512

Application Diagram

The diagram below shows how Rail-Switch II could be utilised in a typical application. The DMX controller is not required if the Rail-Switch II has been preset programmed using RDM, or if it is in test mode.

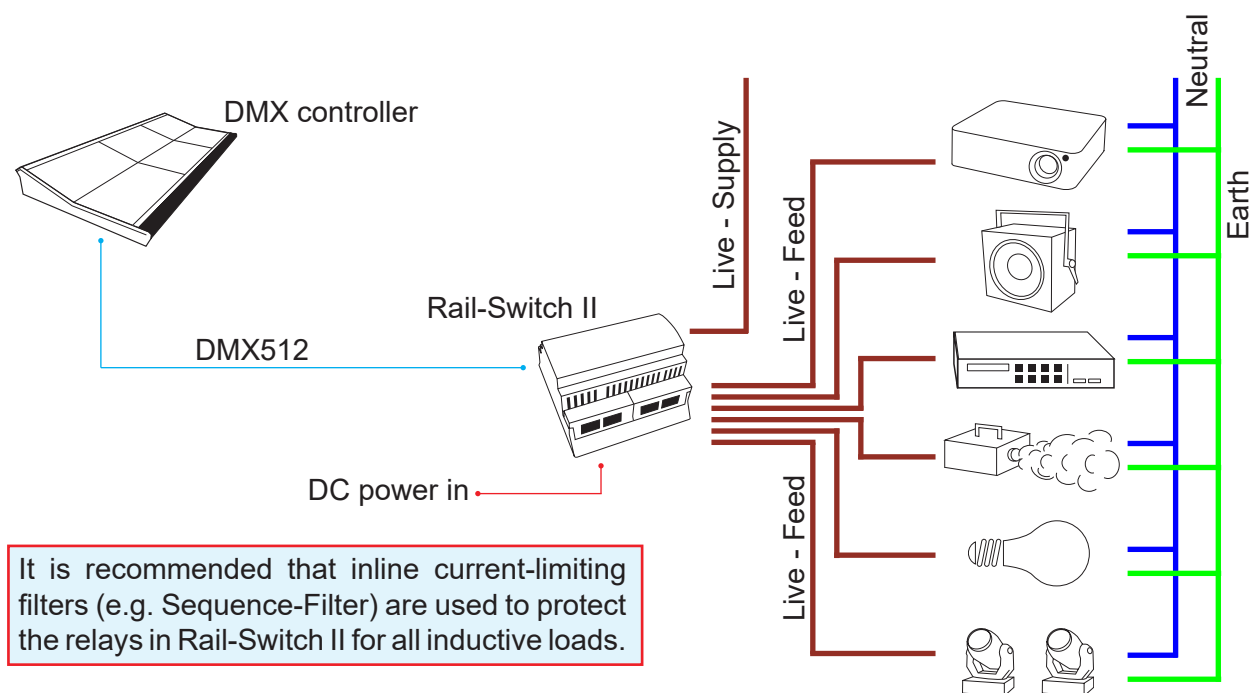

Rail-Switch II Specification

Mechanical <ul style="list-style-type: none">• Housing: DIN Rail Case• Material: Polycarbonate plastic, UL94-V0 rated• Overall dimensions: 90 mm (H) x 88 mm (W) x 62 mm (D)• Weight: 0.2 kg• Mounting: 35 mm DIN Rail or Surface Mount• Country of manufacture: UK	Outputs <ul style="list-style-type: none">• Type: 6 x changeover relay, volt-free contacts• Connectors: 3-pin screw terminals (6 no.)• Maximum switching voltage: 250 VAC• Maximum peak current: 8A• Rated load (AC1 non-inductive): 2,000 VA• Rated load (AC15 inductive): 500 VA• Rated load (Single phase motor): 0.37 kW• Minimum load: 500mW• Protection: User supplied external protection• Isolation: 1 kV between relay contacts
Environmental <ul style="list-style-type: none">• Operating temperature: 0°C to 40°C• Storage temperature: -10°C to +50°C• Operating relative humidity (max): 80% non-condensing• IP rating: IP20 indoor use only• Certification: CE, WEEE, RoHS• Warranty: 2-year (return to base)	Control <ul style="list-style-type: none">• Input Protocols: DMX512, DMX512(1990), DMX512-A• RDM V1.0 (E1.20 - 2006 ESTA Standard)
Power & Electrical <ul style="list-style-type: none">• Input voltage: 9-24 VDC• Input connector: 2-pin pluggable screw terminal (1 no.)• Input power (max): 10 W• Duty cycle: 100% @ 25°C• DC fuse: internal resettable fuse for control electronics	Data Connection <ul style="list-style-type: none">• 3-pin Screw Terminal DMX Input (1 no.)• 4-pin Screw Terminal DMX Loop / Term (1 no.)
DMX512 input <ul style="list-style-type: none">• Input mode: Non-isolated• Input ESD protection: 12 kV• Input voltage protection: +/- 80 V	LED Indication <ul style="list-style-type: none">• Power / DMX / RDM / Preset / Test / RDM locate / Relay
	Configuration <ul style="list-style-type: none">• Commissioner, DMX Workshop• Configurable settings include:<ul style="list-style-type: none">- Start address (individual for each relay)- Preset, data loss and test modes
	Package Contents <ul style="list-style-type: none">• Rail-Switch II• User guide
	Ordering Info <ul style="list-style-type: none">• Product code: Rail-Switch II
	Accessories (not included) <ul style="list-style-type: none">• PSU-24-2-DR

Compliance

All Products manufactured or sold by Artistic Licence Engineering Ltd are fully compliant with the appropriate UKCA, CE and RoHS regulations. Product specific information is available on request.

Waste Electrical & Electronic Equipment (WEEE)

Artistic Licence is a member of a WEEE compliance scheme and will happily recycle any of our products that you, at your expense, return to us.

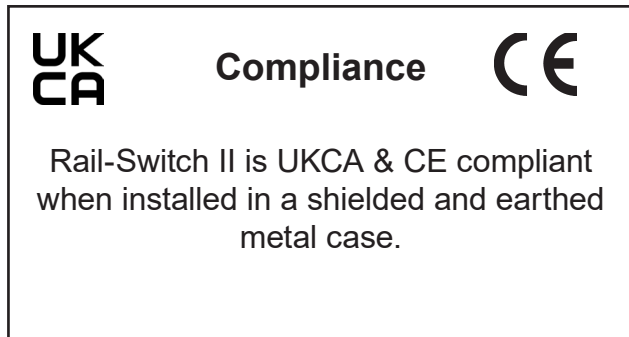

Warranty

All products are covered from date of purchase by a two-year return to base warranty.

By return to base, we mean that the customer is responsible for all costs of transport to and from Artistic Licence.

Returns will not be accepted without prior authorisation. In order to discuss a request to return goods, please email:

Sales@ArtisticLicence.com

Safety Warning

When Rail-Switch II is used for high current or voltages the unit shall be placed within a locked enclosure and shall be connected to the power by a qualified electrician.

All relay connections that are used with high current or voltages shall be externally fused.

This unit has not been designed for domestic use. Proper safety precautions need to be followed when using dangerous voltage or current levels.



Artistic Licence

The Mould Making Workshop
Soby Mews
Bovey Tracey
TQ13 9JG
United Kingdom

Telephone +44 (0) 20 8863 4515

Email: Sales@ArtisticLicence.com

Web: www.ArtisticLicence.com

Support@ArtisticLicence.com

Due to our policy of continuing product improvement specifications are subject to change without notice

