

Showline

SL WASH 180

PHILIPS



The Showline SL WASH 180 moving LED is part of a range of LED luminaires designed for the entertainment market providing rugged construction combined with high performance LED sources. Showline luminaires are designed to work together to match color, dimming and operation simplifying set up and allowing you to plan your production knowing you will get consistent light from every luminaire.

The Showline SL WASH 180 is a powerful moving LED wash luminaire available in a small and light weight configuration. This powerful RGBW luminaires deliver exceptional light output. The luminaire designed a wide range of beam angle projection from 12 - 45 degree, zoom control by DMX signal. The unique design of the SL WASH 180 offers the high speed Pan / Tilt movement with wide angle range of rotation. The SL WASH 180 includes standard mounting brackets for floor or pipe mount. Mounting brackets feature secure lock off and a tight profile to insure close placement to insure smooth beam spreads. Units are designed with cable management for clean cabling and easy set up.

Features :

- Rugged Construction
- Philips LumiLeds RGBW LED's for exceptional output and color
- Built-in color presets, effects and chases
- HSIC (Hue - Saturation - Intensity - Color temperature) operation mode
- 8 or 16-bit DMX-512A operation for smooth stepless fades
- On-board LCD Menu System for addressing and setup
- Remote configuration available via RDM
- PowerCon in and thru power connections
- 5-pin DMX-512A(RDM) in and thru connections

Drawing Diagram :

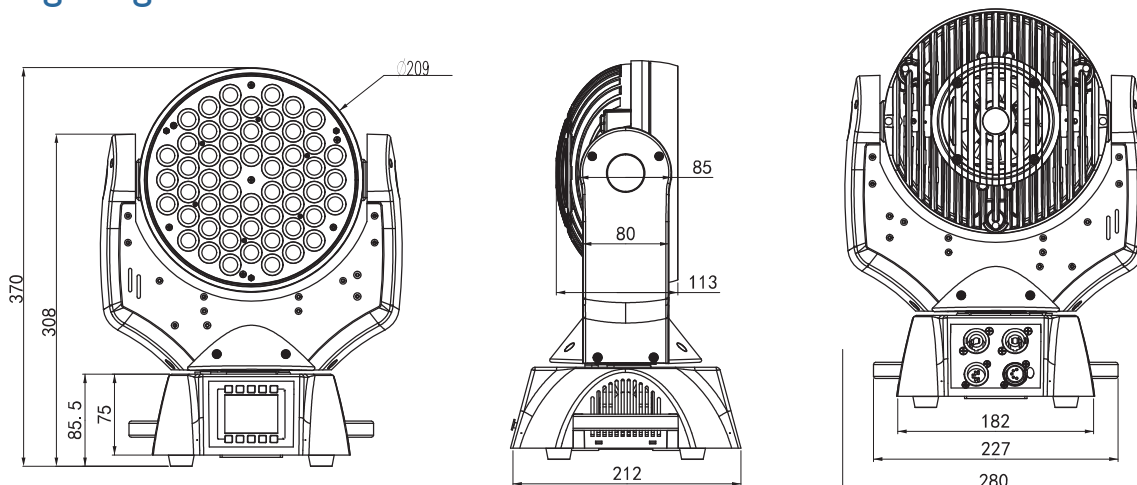

Technical Specifications :

Version:
SL WASH 180 RGBW, IP20

Optics:
12 - 45 degree Zoom
54 high power LEDs

Controls:
DMX-512A(RDM)
Local LCD control
Master/slave

Physical:
90-240VAC, 180W
370mm x 280mm x 212mm, 8kg
CE

Luminance:
3475 lumens
CRI/CQS:
>90 (RGBW)

Features:
Color Gel filter preset
Chase - Strobe + Duration Effect Engine
LED & Tungsten Curves selection
Pan/Tilt shape Effect Engine

Modes:
HSIC
8 bit RGBW
16 bit RGBW

Ordering Information :

SLI80

SL WASH 180 RGBW Moving LED

Harmonize Color Calibration Technology

At the heart of all Showline products is Philips Harmonize Calibration technology. Harmonize is a proprietary, advanced LED color matching system, consisting of 3 correction modules: RGB, RGBW and Cool White/Warm White. Every Showline fixture undergoes rigorous testing to provide you with consistent control of color and intensity as well as output of the highest quality.

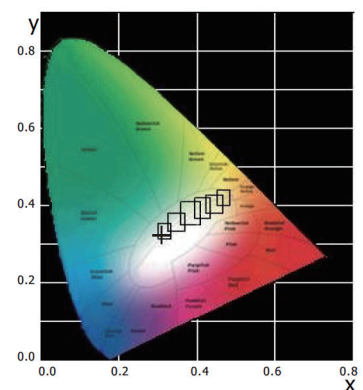

Philips Group 2012. All rights reserved.

The Company reserves the right to make any variation in design or construction to the equipment described. E&OE. Philips Entertainment delivers fully integrated lighting solutions; from simple lamps to complete systems designed with the specific needs of the entertainment and specialized display lighting markets.

Philips Entertainment U.S.
10911 Petal Street
Dallas, TX 75238
Tel: +1 214647 7880
Fax: +1 214647 8030

Philips Entertainment Lighting Asia Limited
Unit C, 14/F, Roxy Industry Centre
No. 41 - 49 Kwai Cheong Road
Kwai Chung, N.T. Hong Kong
Tel: +852 27969786
Fax: +852 27986546

Philips Entertainment Group Europe
Rondweg Zuid 85
Winterswijk 7102 JD Netherlands
Tel: +31 543-542343
Fax: +31 53 4500425

Philips Entertainment New Zealand
19 - 21 Kawana Street, Northcote
Auckland 0627, New Zealand
Tel: +64 9481 0100
Fax: +64 9481 0101